

# PECASA REGALSYSTEM

—

Pecasa système d'étagères  
Pecasa shelf system

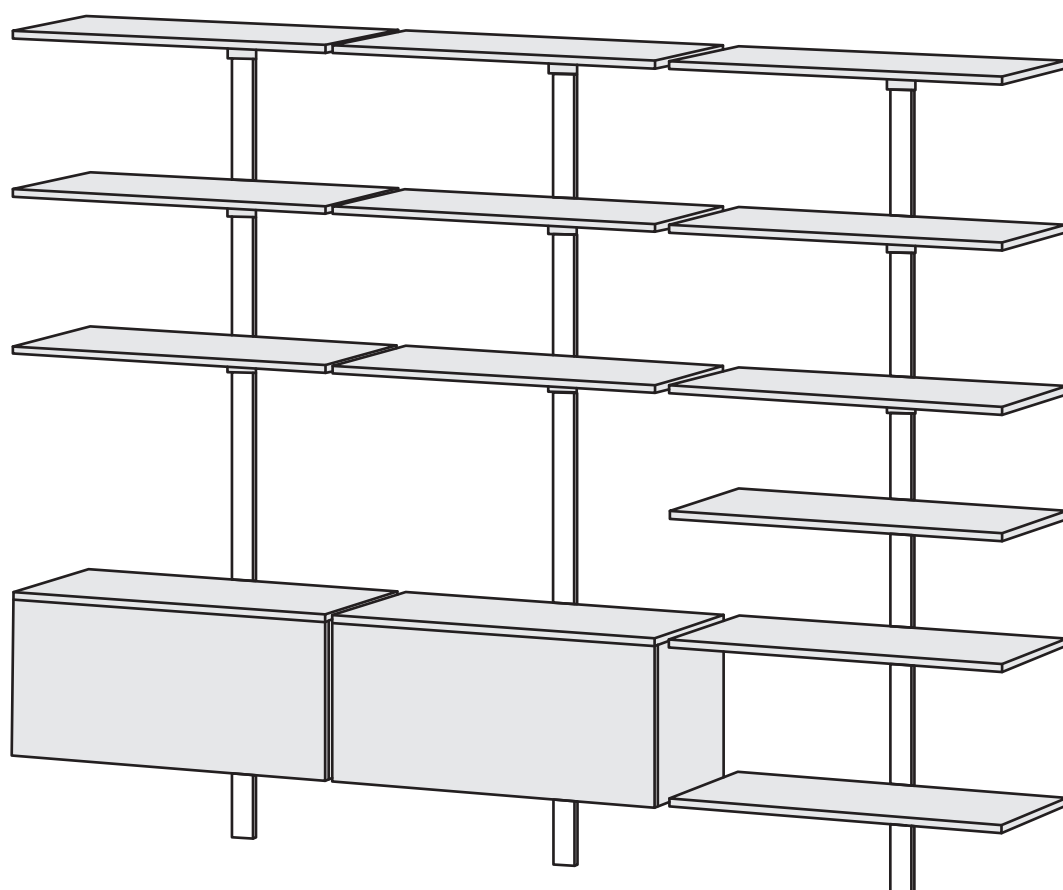



**DE** Für Pecasa ist eine fachkundige Montage erforderlich, denn unsachgemäße Montage kann zu Unfällen führen; Möbel/Gegenstand könnte kippen oder umfallen. **WICHTIG!** Schrauben oder Beschläge zur Wand-/Deckenbefestigung sind nicht beige packt. Achten Sie darauf, dass Sie Schrauben/Beschläge entsprechend der Wandbeschaffenheit und mit ausreichender Tragfähigkeit verwenden. Erkundigen Sie sich gfs. beim Eisenwarenfachhandel.

**FR** Montage professionnel requis. Un montage incorrect peut entraîner des accidents ; les meubles / objets peuvent basculer ou tomber. **IMPORTANT !** Les vis ou les armatures pour la fixation au plafond / murale ne sont pas comprises. Veuillez à utiliser des vis / armatures adaptées à la constitution du mur et affichant une capacité de charge suffisante. Le cas échéant, renseignez-vous en quincaillerie.

**EN** Expert assembly required. Improper assembly could cause accidents; furniture/objects could topple or fall over. **IMPORTANT!** The pack does not include screws or fittings for fixing the system to the wall/ceiling. Make sure that you use screws/fittings that are suitable for the wall's condition and have sufficient load-bearing capacity. If necessary, check at a hardware store.

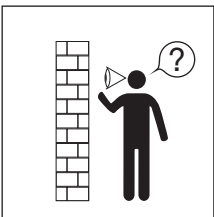

**DE** Wandbeschaffenheit prüfen.  
**FR** Vérifier la constitution du mur.  
**EN** Check wall condition.

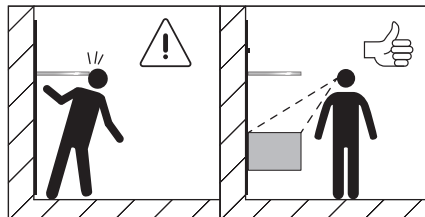

**DE** ACHTUNG bei Montage eines Glastablars auf Augenhöhe! Aus Gründen der Sichtbarkeit immer einen massiven Körper darunter montieren.  
**FR** ATTENTION en cas de montage d'une étagère en verre à la hauteur des yeux ! Pour des raisons de visibilité, toujours monter un caisson massif au-dessous.  
**EN** CAUTION: If mounting a glass shelf at eye level, always fit a large cabinet or box underneath it to boost its visibility.



**DE** Beratung durch Fachpersonal.  
**FR** Conseils par des professionnels.  
**EN** Consult a professional.

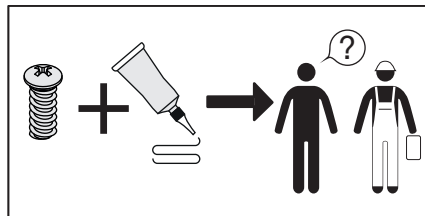

**DE** Montage mit Kleber vom Fachmann abklären lassen. ! Muss für den vorgesehenen Verwendungszweck geeignet sein.  
**FR** Se faire expliquer le montage avec de la colle par un professionnel. ! Doit être adapté pour l'utilisation prévue.  
**EN** Consult a professional for advice about using glue for assembly. ! The glue must be suitable for the intended use.

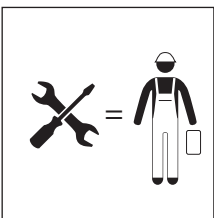

**DE** Montage durch Fachpersonal.  
**FR** Montage par des professionnels.  
**EN** Must be installed by a professional.

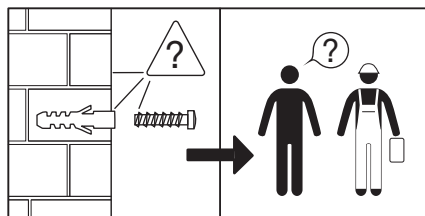

**DE** Schrauben oder Beschläge zur Wandbefestigung durch Fachmann abklären lassen.  
**FR** Se faire expliquer par un professionnel les vis ou les armatures pour la fixation murale.  
**EN** Consult a professional for advice about the screws or fittings to use to fix the system to the wall.



**DE** Bei fehlerhafter Montage droht Gefahr durch herunterfallende Elemente.  
**FR** En cas de montage erroné, des éléments risquent de tomber.  
**EN** If the system is not installed correctly, elements may fall down.



Bauart geprüft  
Sicherheit  
Regelmäßige  
Produktions-  
überwachung

www.tuv.com  
ID 1111217520



Tablarträger-Set für Glas und Holzwerkstoffe  
 Jeu de supports d'étagère pour verre et dérivés du bois  
 Shelf support set for glass or wood-composite shelves

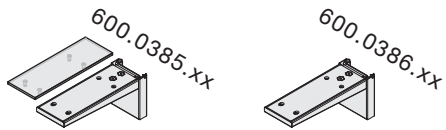

Tablarträger-Set für Massivholz  
 Jeu de supports d'étagère pour bois massif  
 Shelf support set for solid wood shelves



Möbelträger-Set  
 Jeu de supports de meuble  
 Unit support set

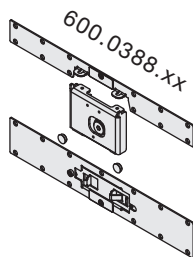

Wandprofil-Set  
 Jeu de profils muraux  
 Wall profile set

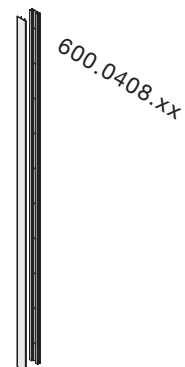

Metalltablar, inkl Tablarträger Étagères en métal avec supports Metal shelf, incl. shelf supports	Breite Largeur Width	Tiefe Profondeur Depth	Dicke Épaisseur Thickness	Max. zulässige Zuladung Max. load capacity Max. capacité de charge
---	----------------------------	------------------------------	---------------------------------	--

Vorgeschriebene Tablar-Dimensionen  
Dimensions de l'étagère prescrits  
Prescribed shelf dimensions

850 mm

400 mm

19 mm

60 kg

Die Tragkraft ist abhängig von Materialart und Dimensionierung.  
Capacité de charge en fonction du type de matériau et des dimensions.  
Load capacity depends on material type and dimensions.

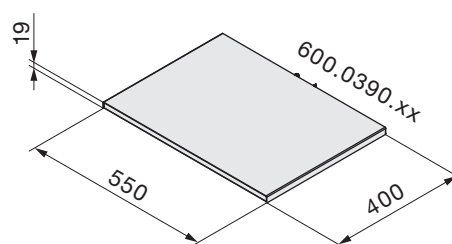
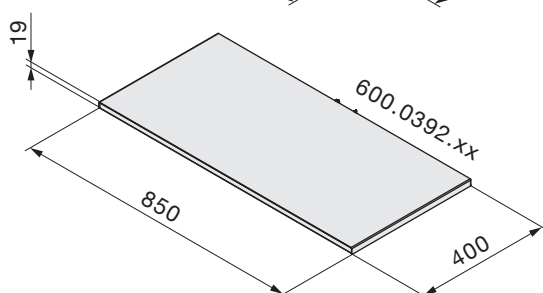
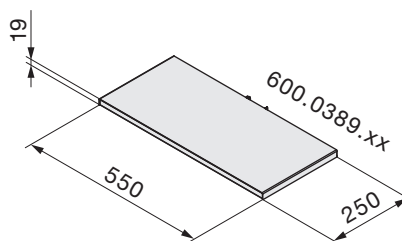
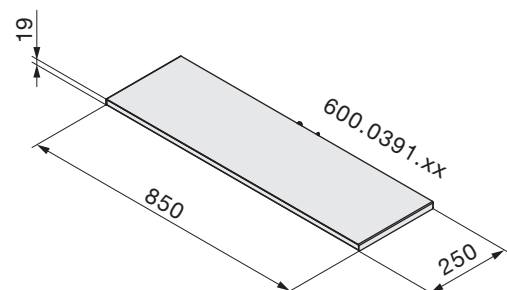

Glastablar Étagère en verre Glass shelf	Breite Largeur Width	Tiefe Profondeur Depth	Dicke Épaisseur Thickness	Max. zulässige Zuladung Max. load capacity Max. capacité de charge
---	----------------------------	------------------------------	---------------------------------	--

Vorgeschriebene Tablar-Dimensionen  
Dimensions de l'étagère prescrits  
Prescribed shelf dimensions

≤ 850 mm

≤ 400 mm

8 mm

30 kg

Die Tragkraft ist abhängig von Materialart und Dimensionierung.  
Capacité de charge en fonction du type de matériau et des dimensions.  
Load capacity depends on material type and dimensions.

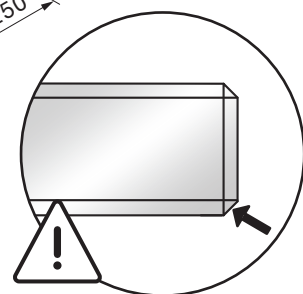
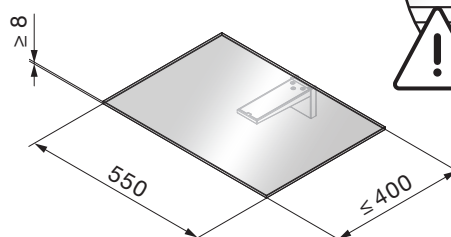
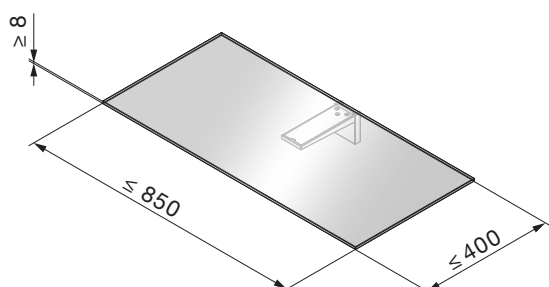
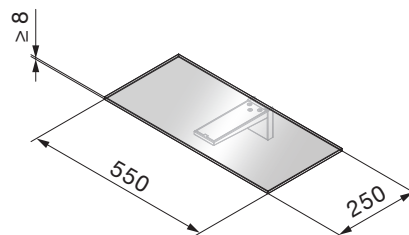
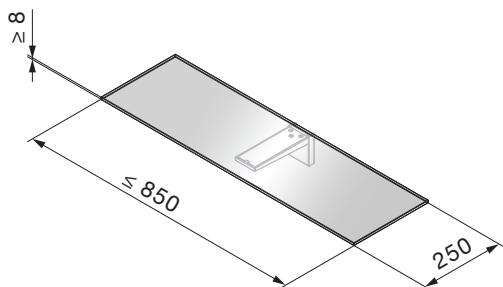

Tablar aus Holzwerkstoffen Étagère en dérivés du bois Wood-composite shelf	Breite Largeur Width	Tiefe Profondeur Depth	Dicke Épaisseur Thickness	Max. zulässige Zuladung Max. load capacity Max. capacité de charge
Vorgeschriebene Tablar-Dimensionen Dimensions de l'étagère prescrits Prescribed shelf dimensions	≤ 850 mm	≤ 400 mm	19 mm	30 kg
	≤ 850 mm	≤ 400 mm	30 mm	50 kg

Die Tragkraft ist abhängig von Materialart und Dimensionierung.

Capacité de charge en fonction du type de matériau et des dimensions.

Load capacity depends on material type and dimensions.

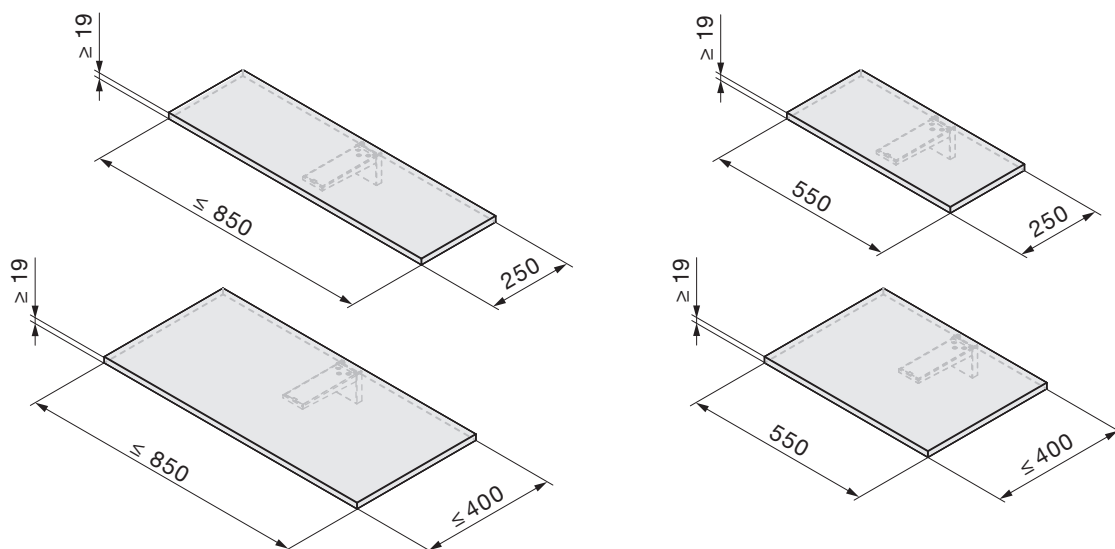

Tablar aus Massivholz Étagère en bois massif Solid wood shelf	Breite Largeur Width	Tiefe Profondeur Depth	Dicke Épaisseur Thickness	Max. zulässige Zuladung Max. load capacity Max. capacité de charge
Vorgeschriebene Tablar-Dimensionen Dimensions de l'étagère prescrits Prescribed shelf dimensions	≤ 850 mm	≤ 400 mm	19 mm	60 kg
	≤ 850 mm	≤ 400 mm	30 mm	80 kg

Die Tragkraft ist abhängig von Materialart und Dimensionierung.

Capacité de charge en fonction du type de matériau et des dimensions.

Load capacity depends on material type and dimensions.

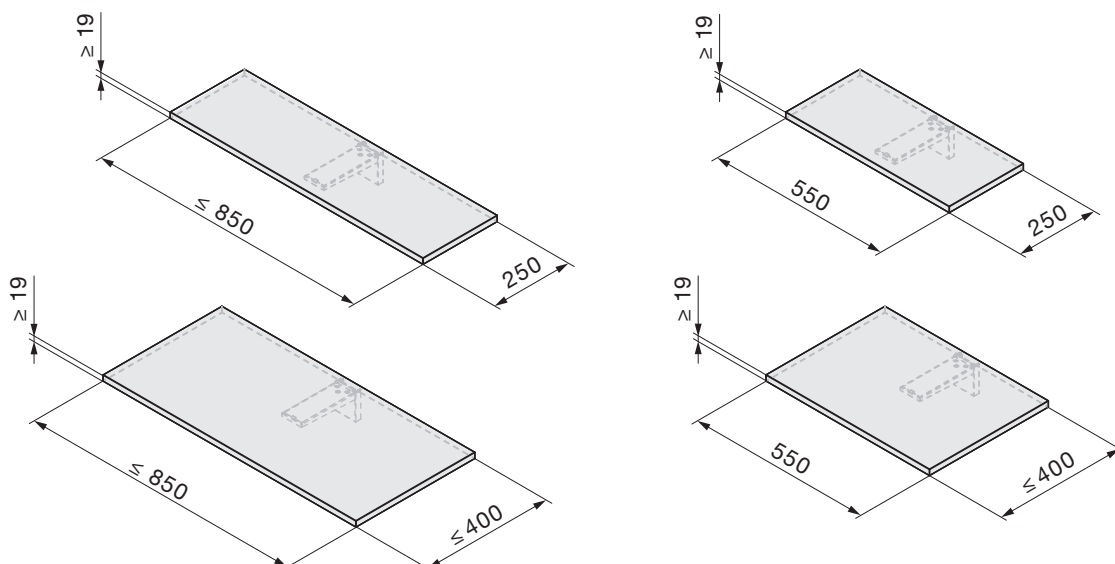

Korpus  
Caisson  
Cabinet

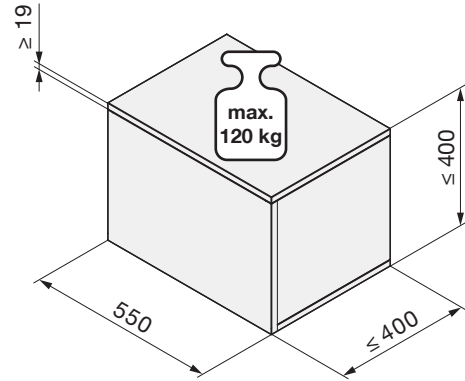
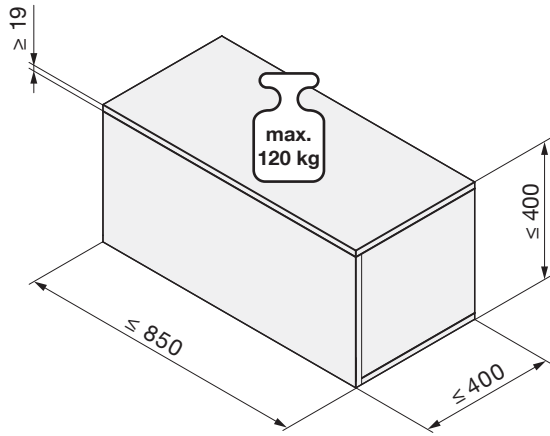

Fach  
Compartment  
Box

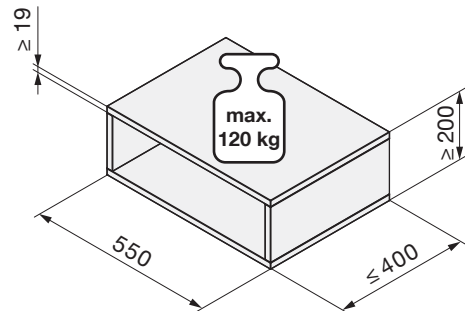
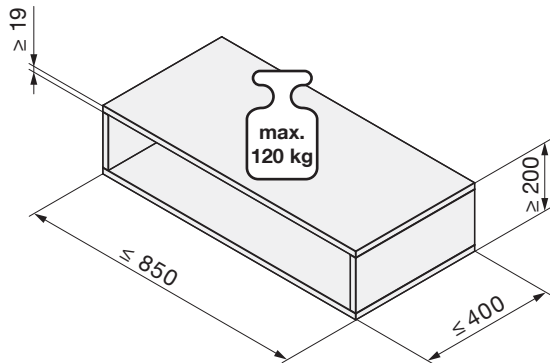

Office  
Bureau  
Office

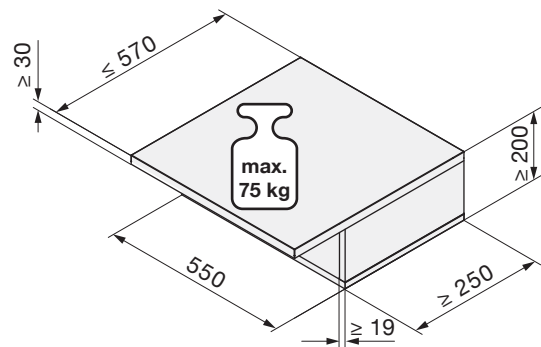
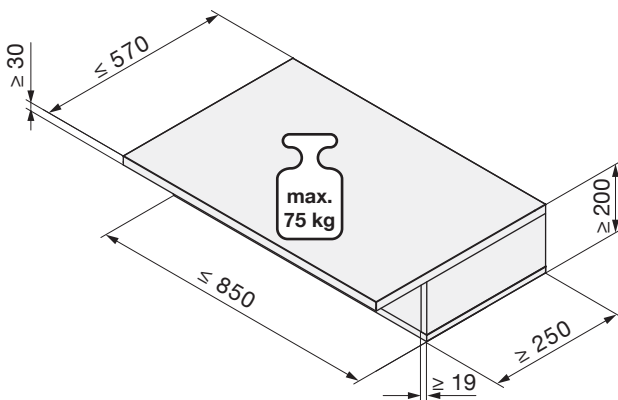

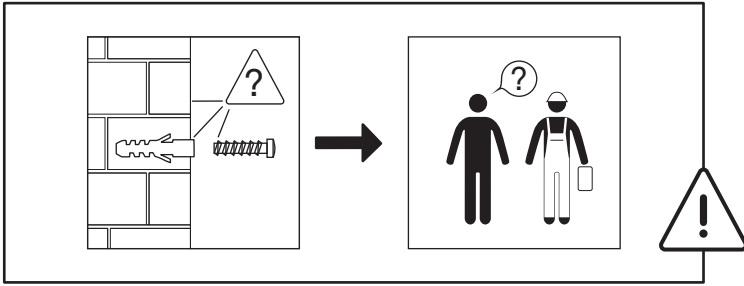

600.0418.xx

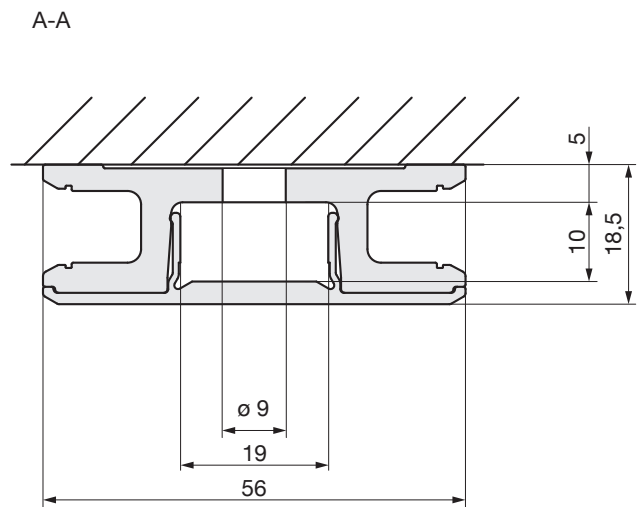
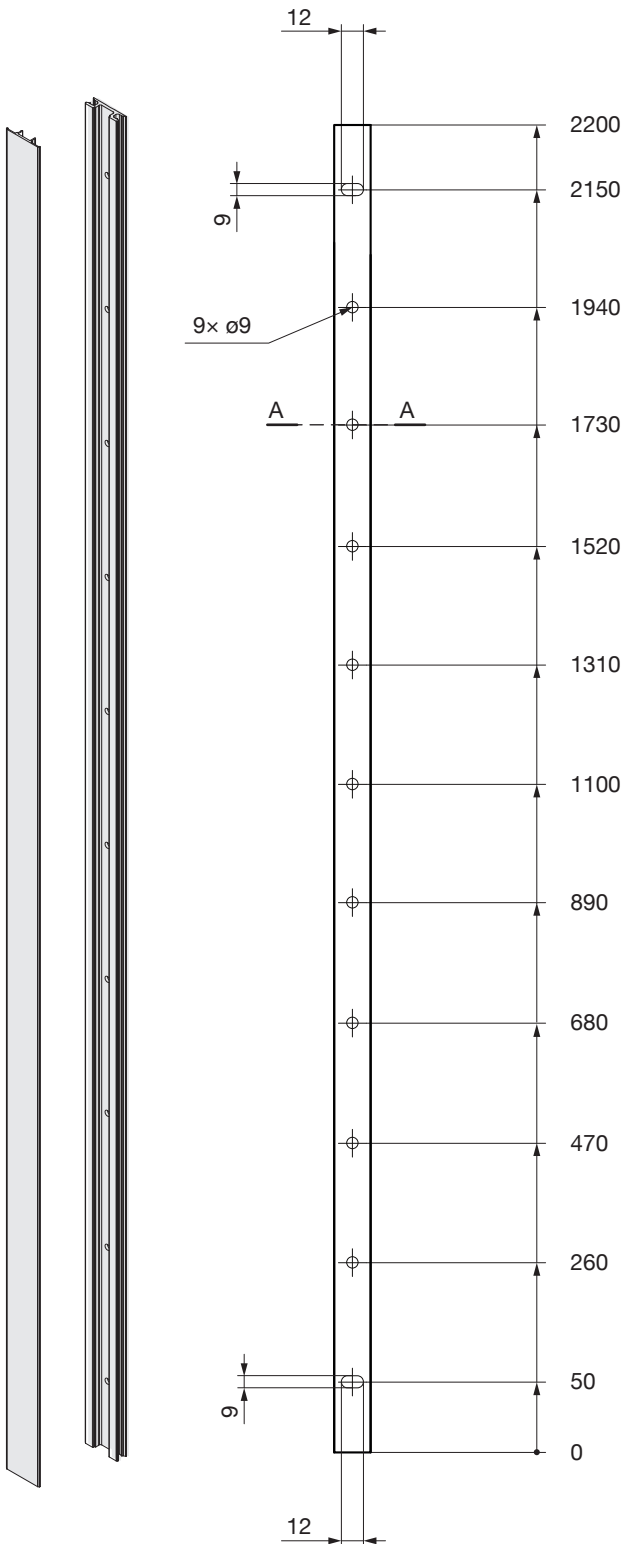

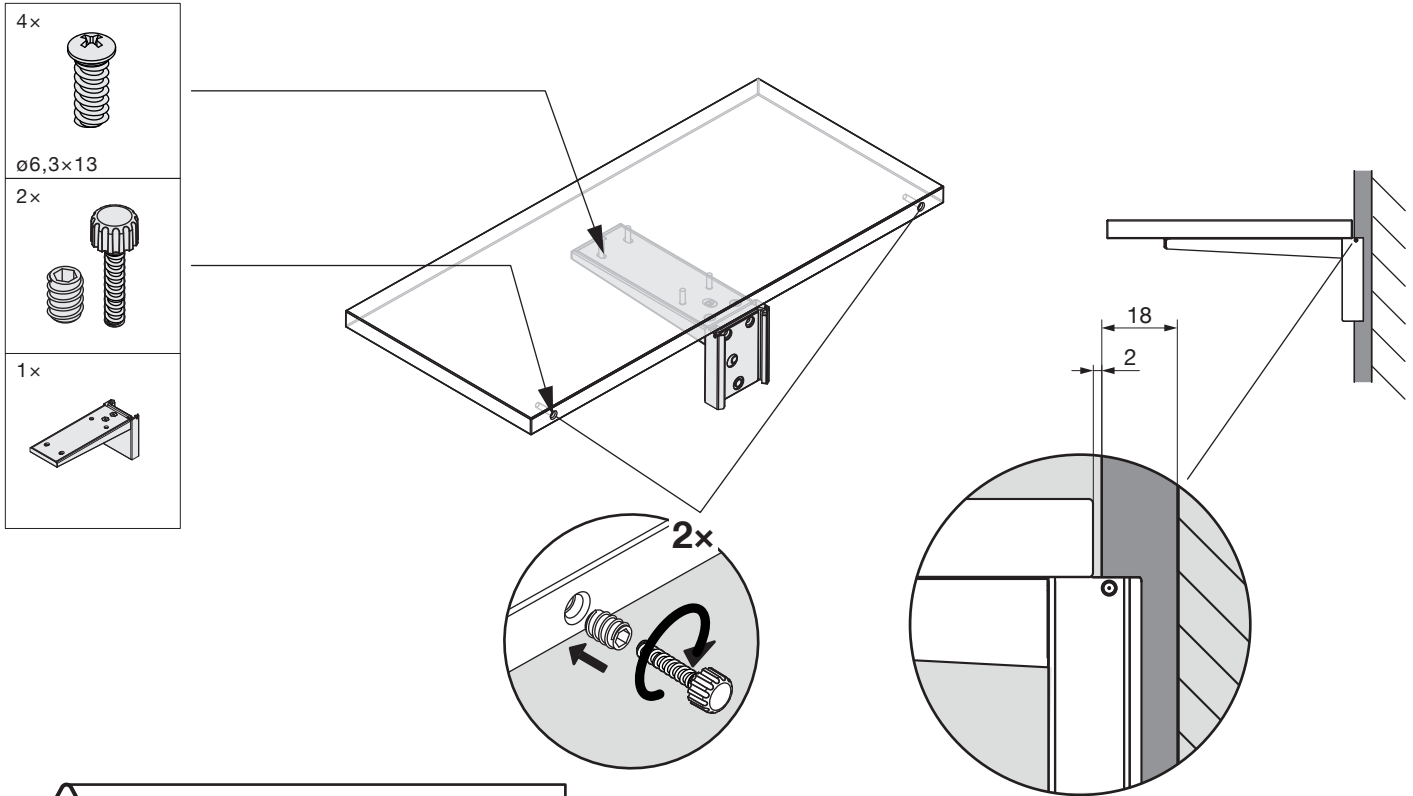

**!** Verwendungszweck: Holz + Metall  
Utilisation : bois + métal  
Suitable for use with wood + metal

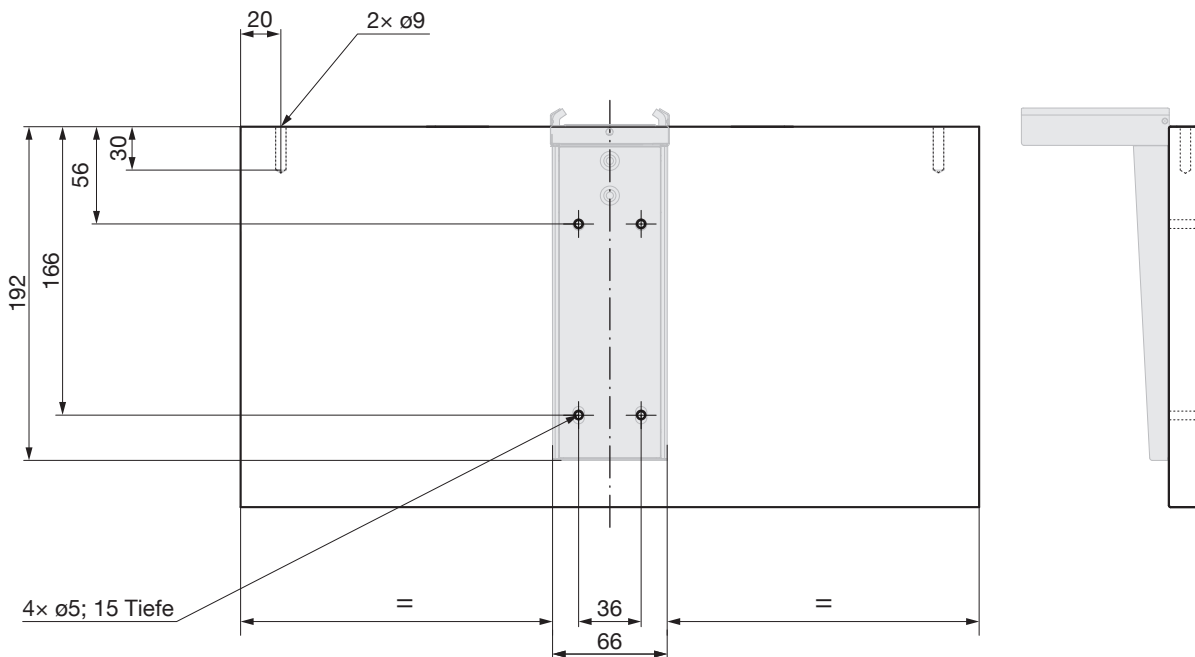
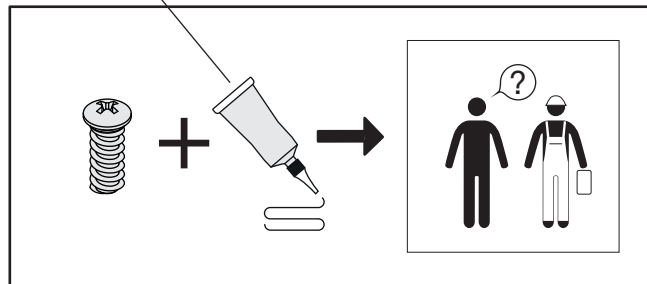



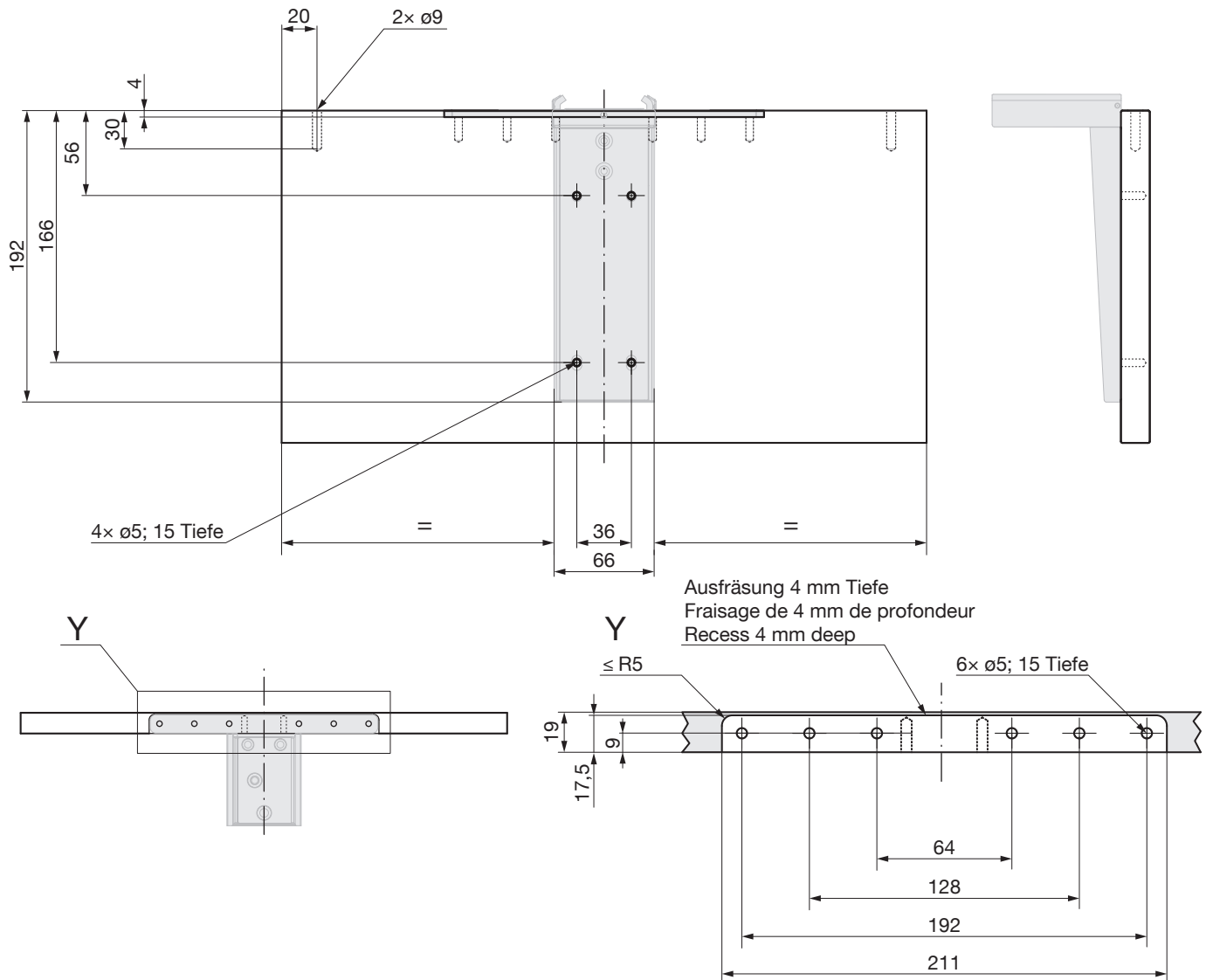
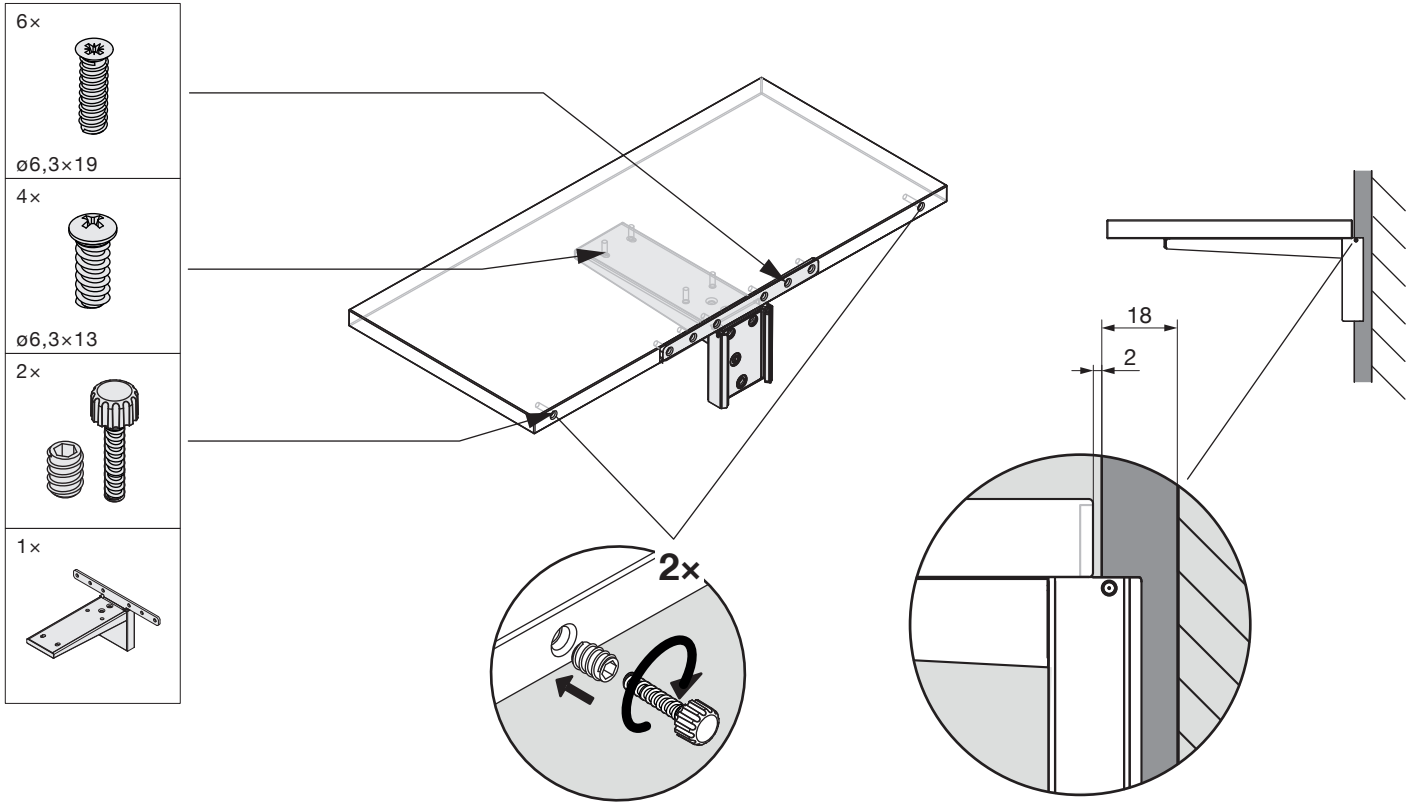

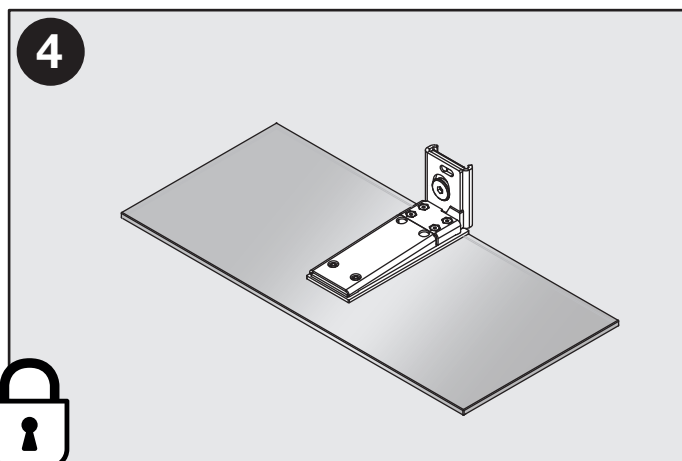
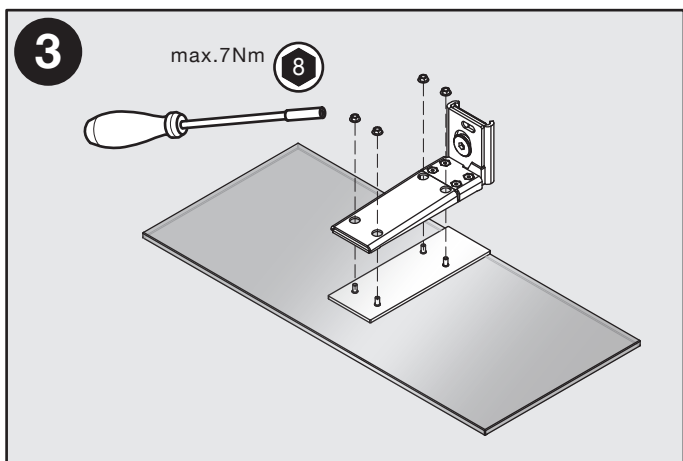
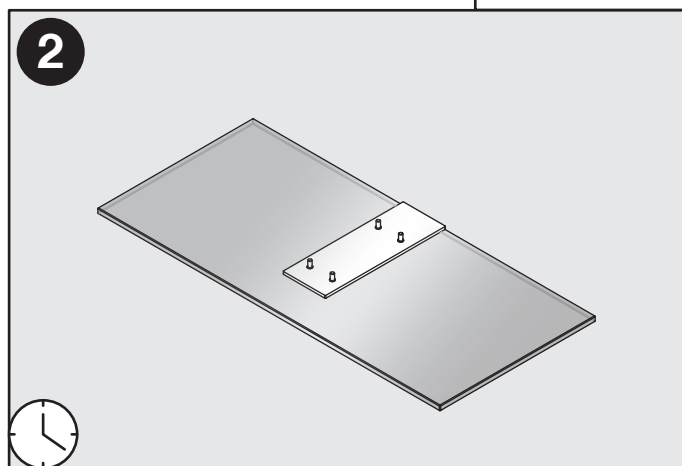
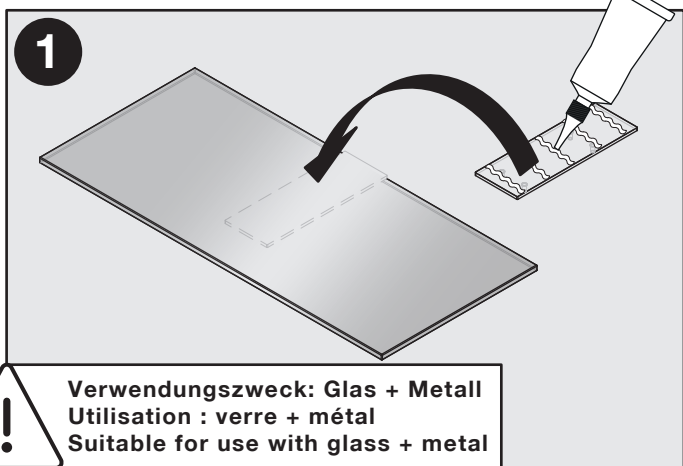
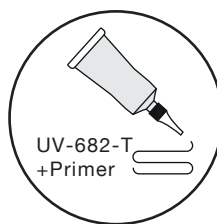
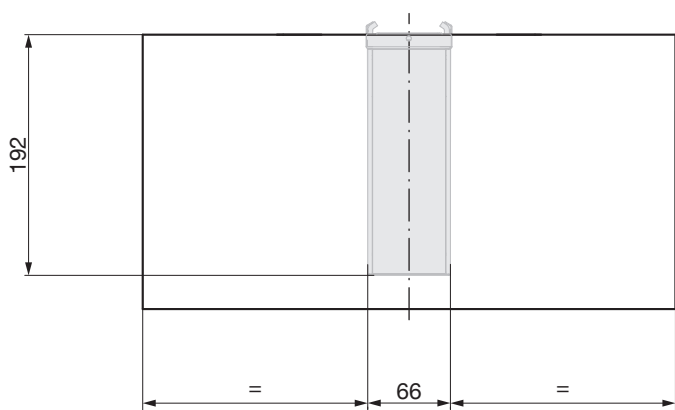
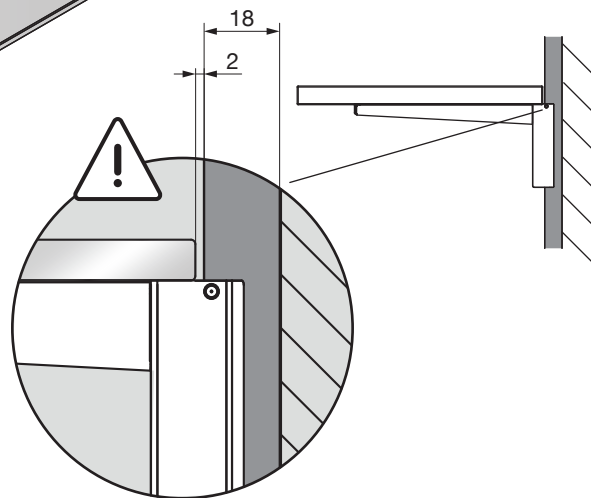
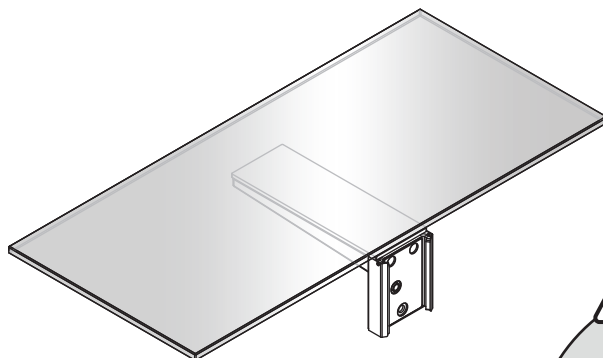
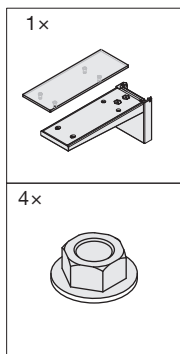

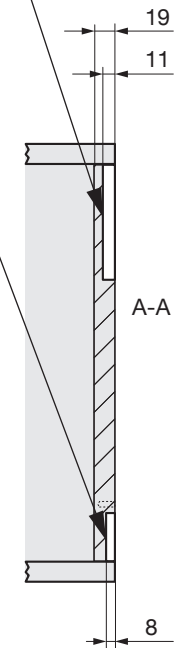
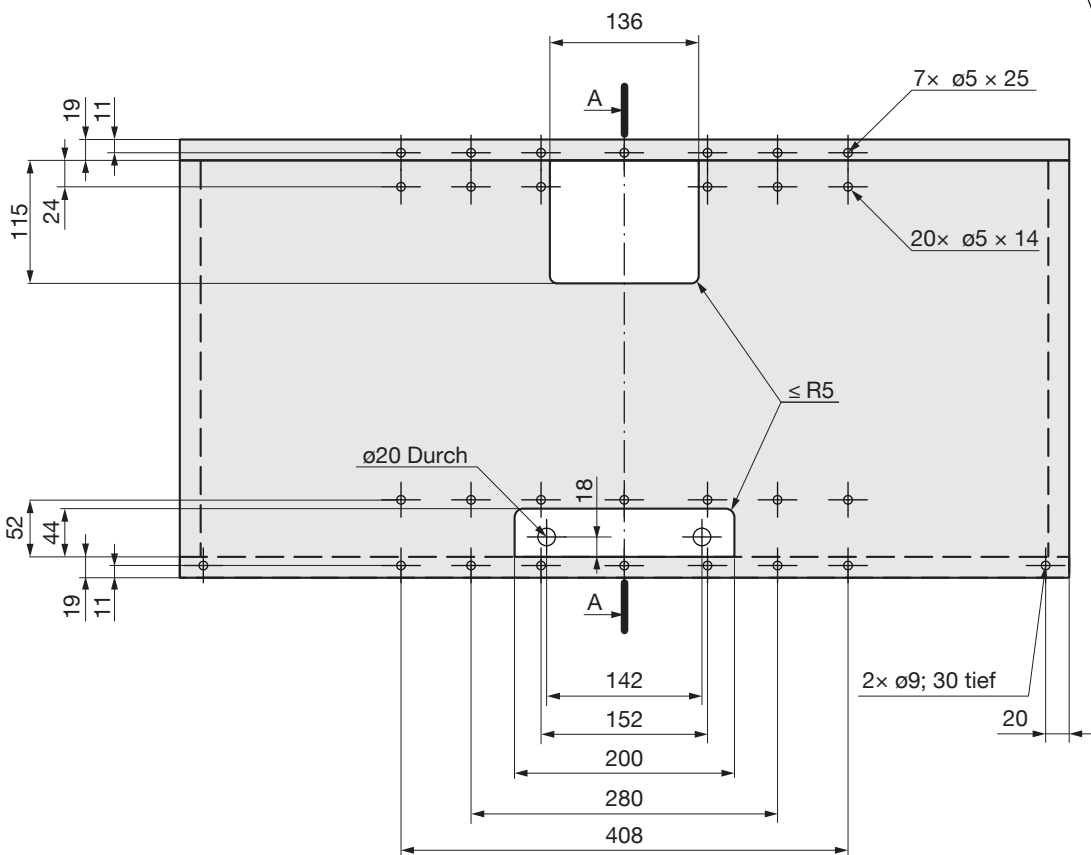
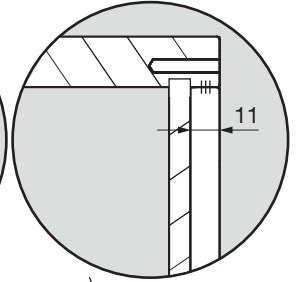
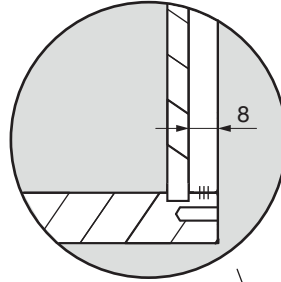
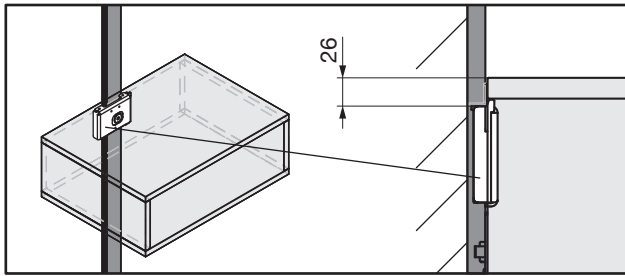
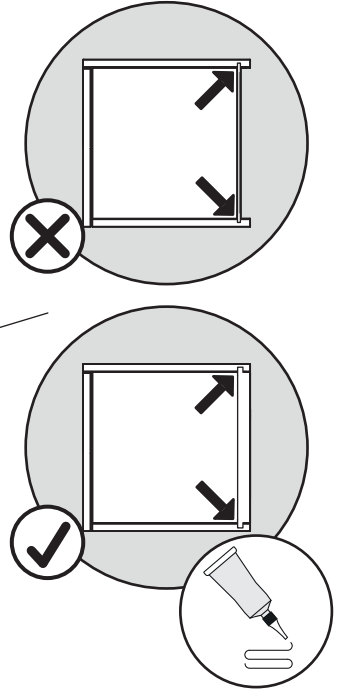
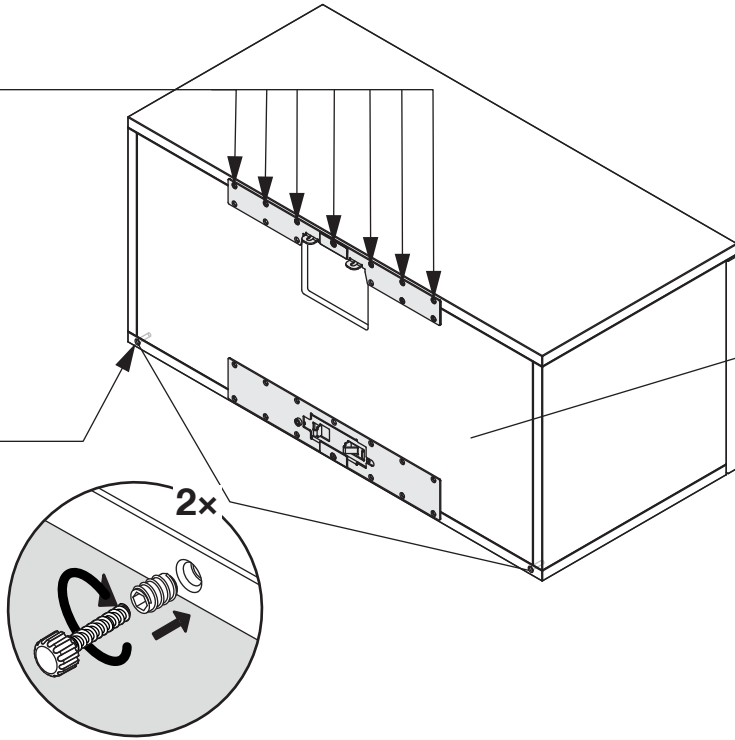
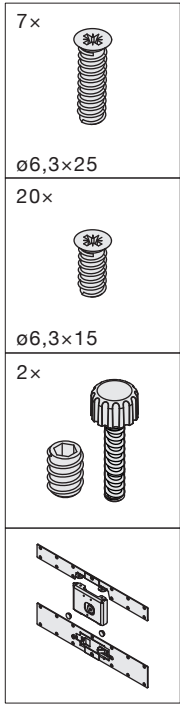

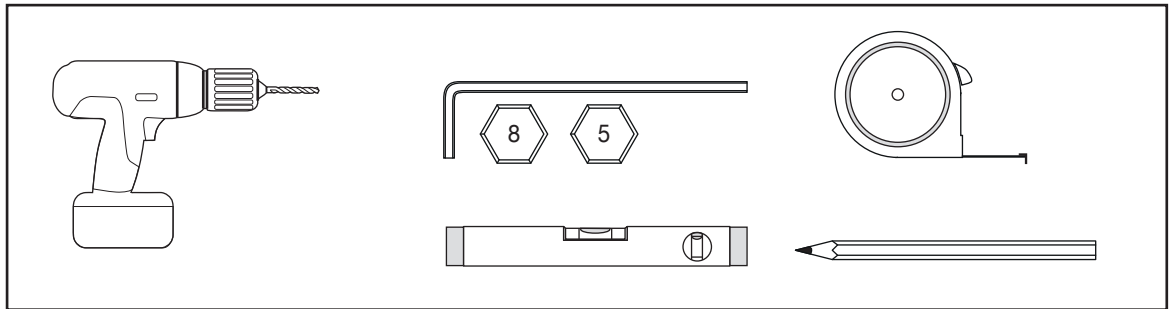
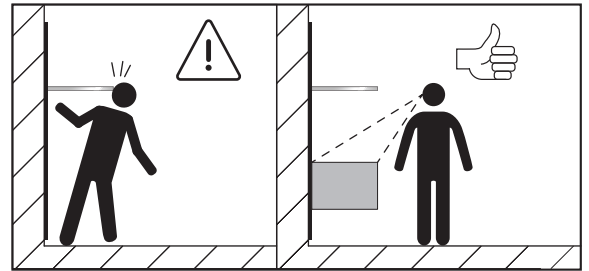
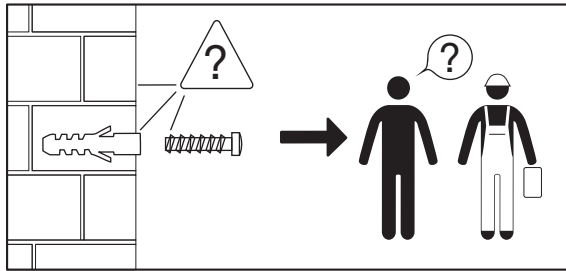
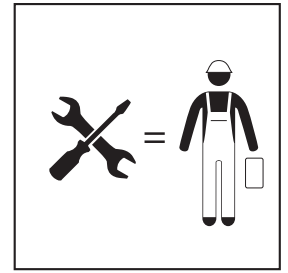
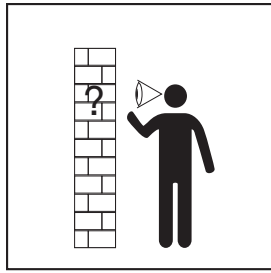

1

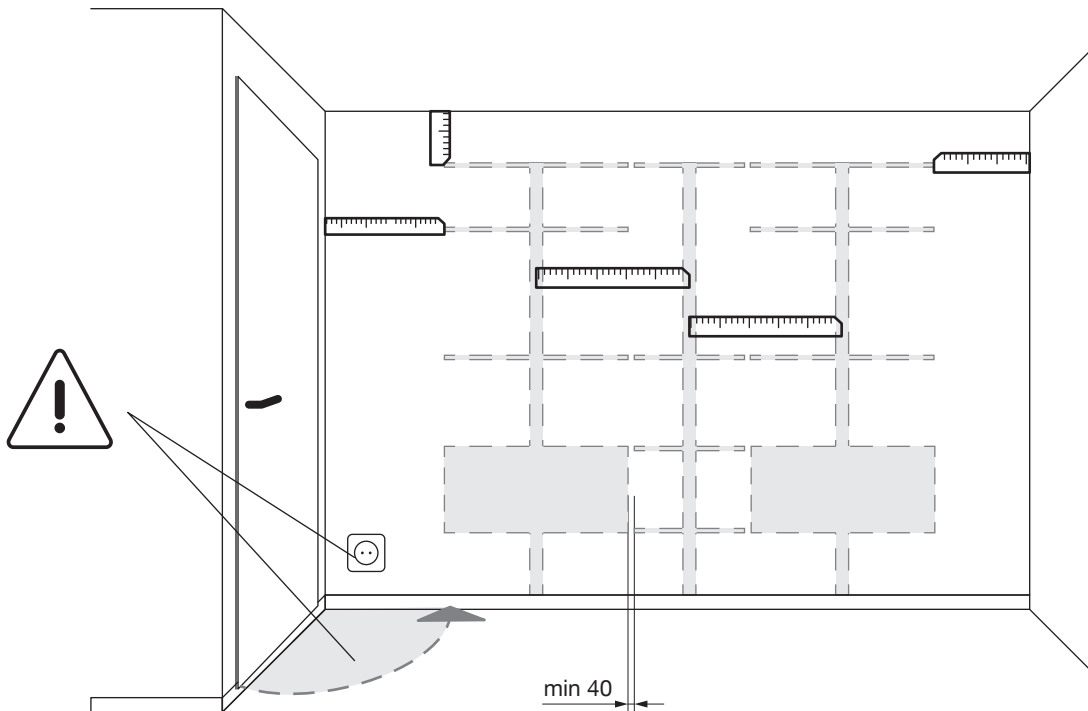

2

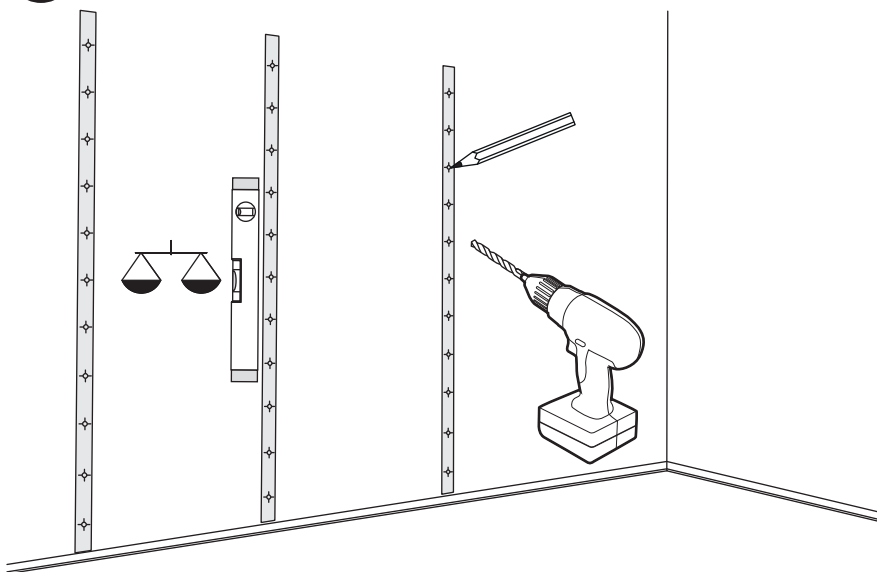

3

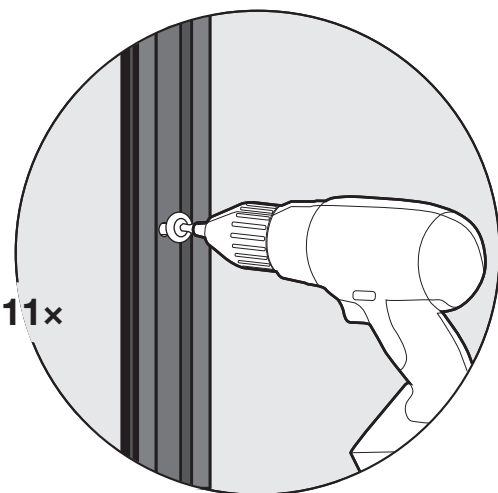
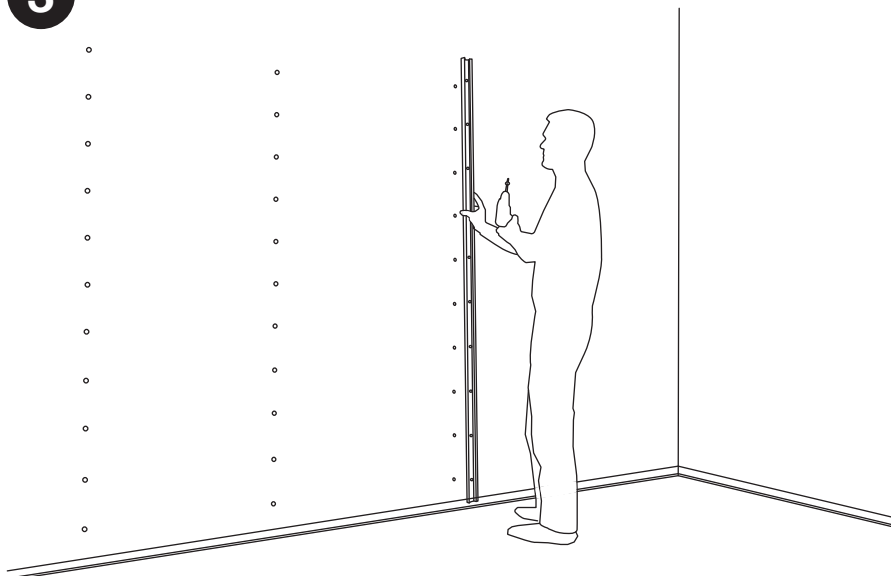

4

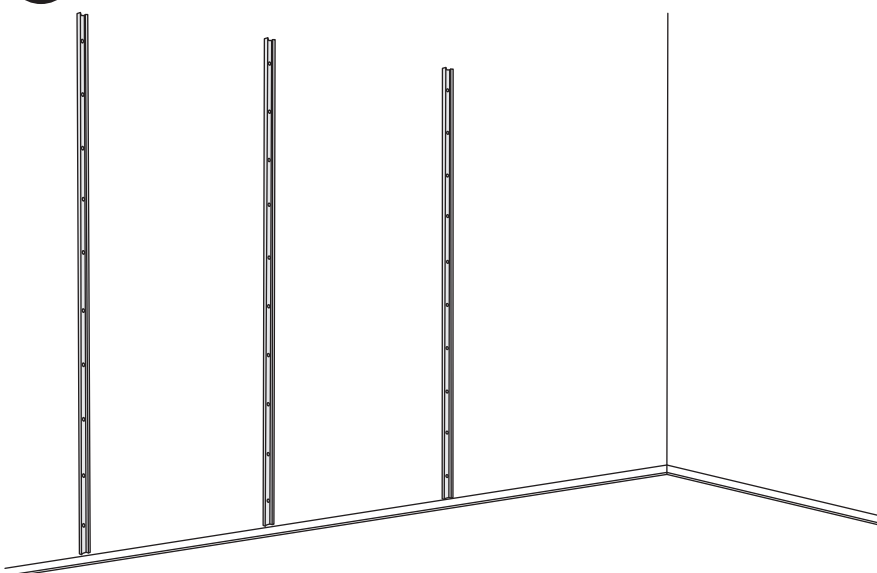

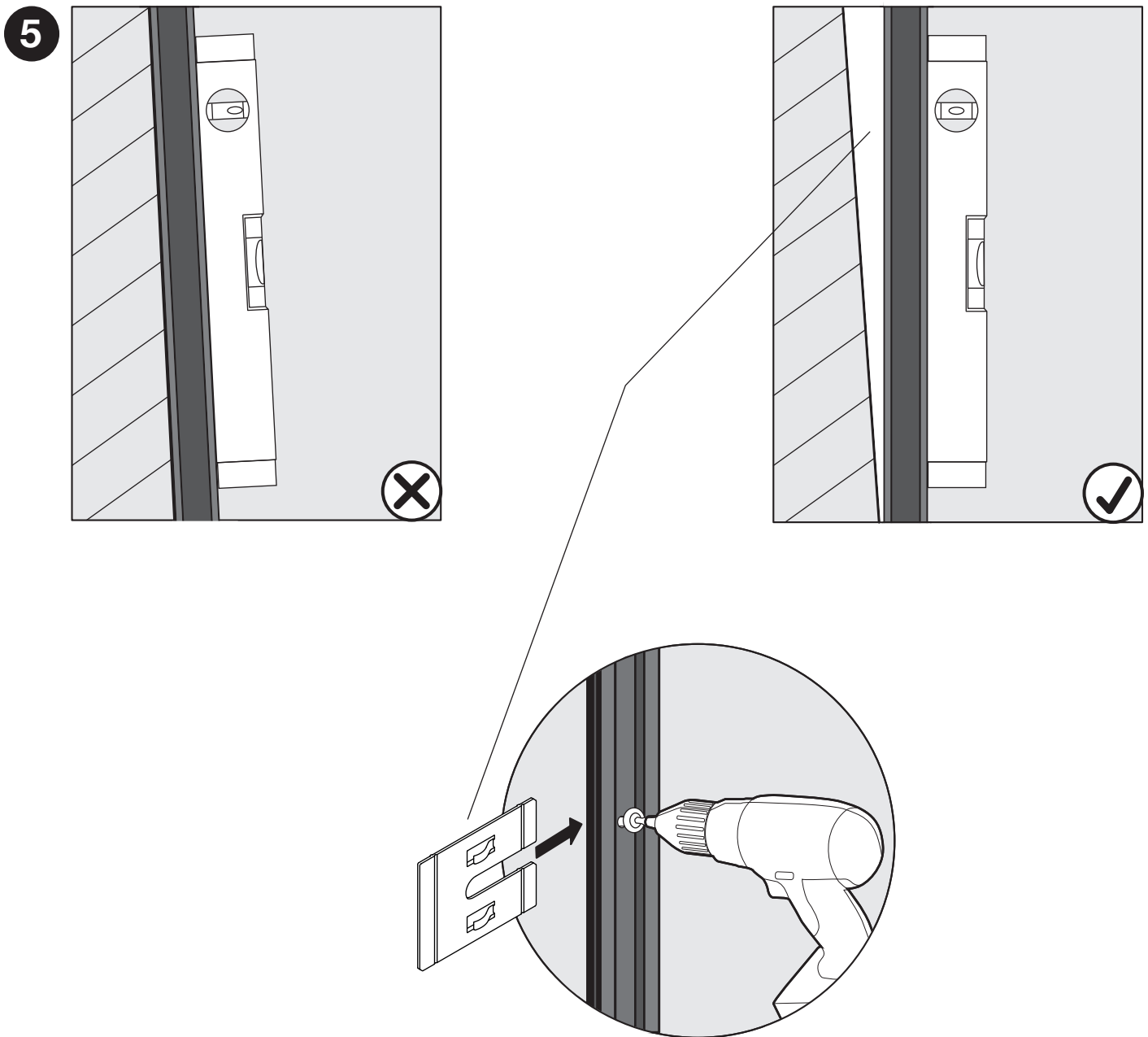
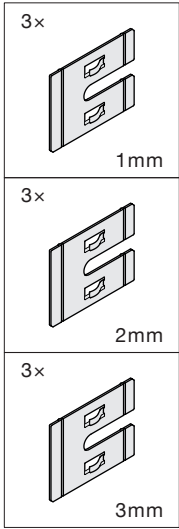

6

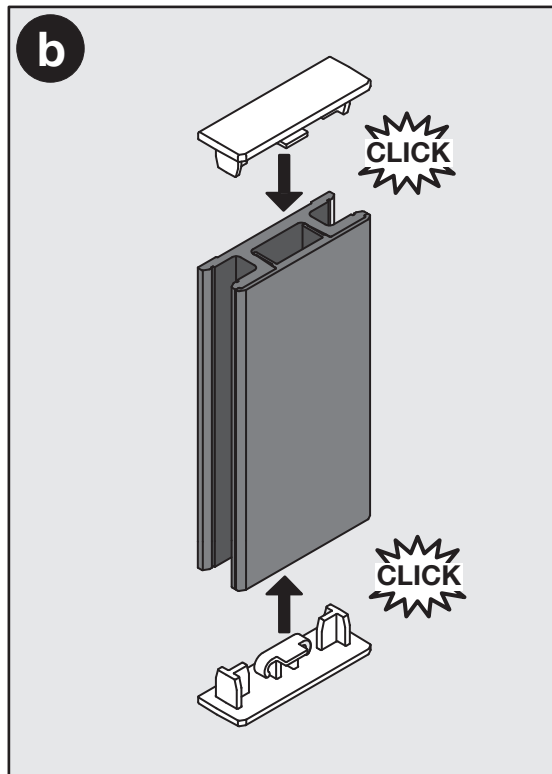
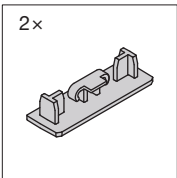
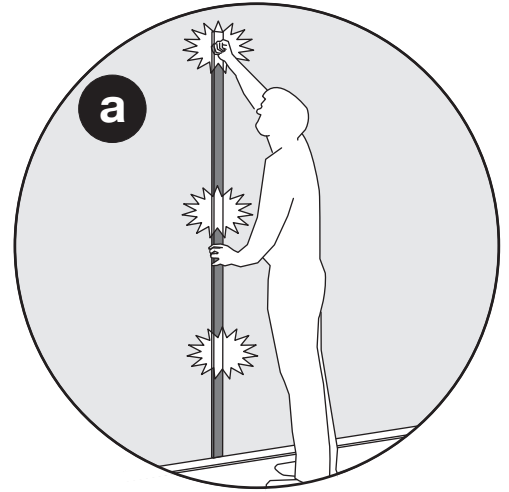
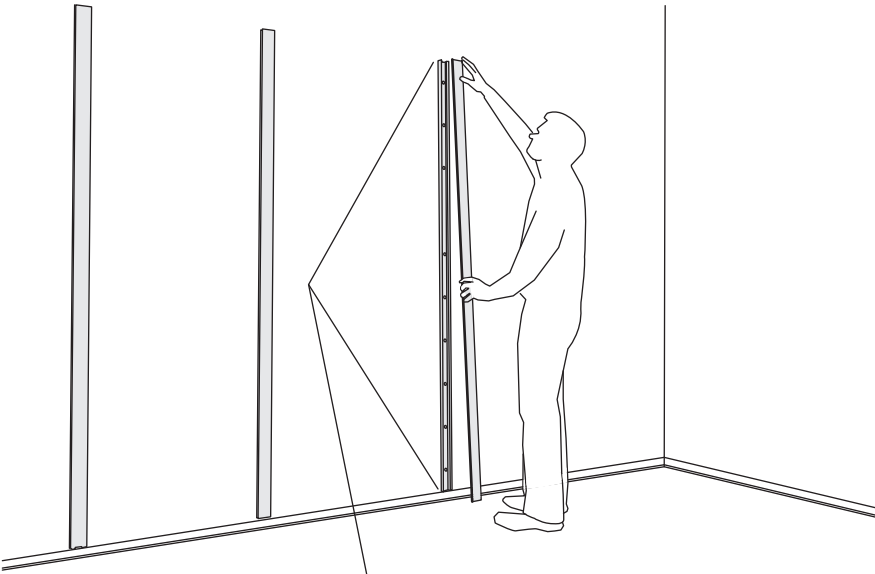

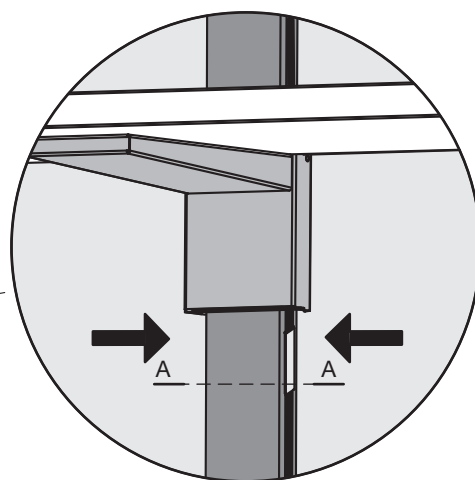
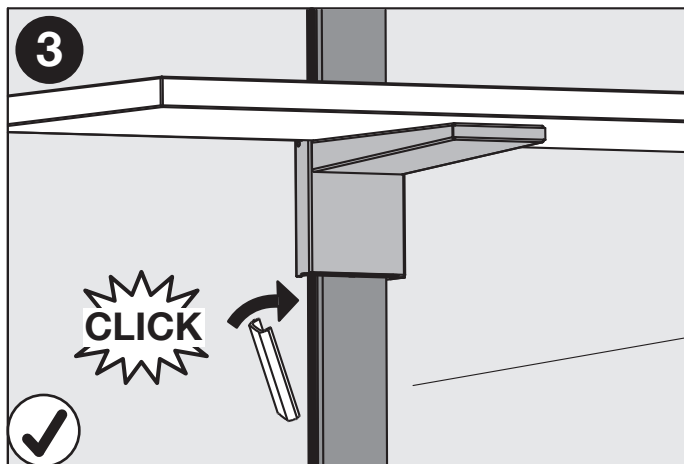
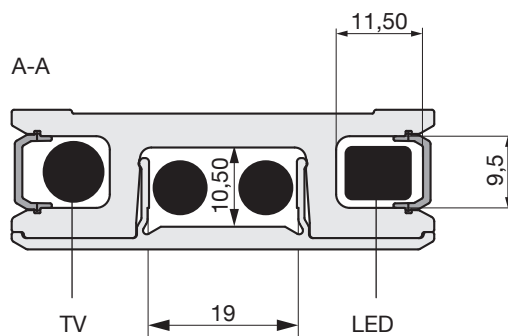
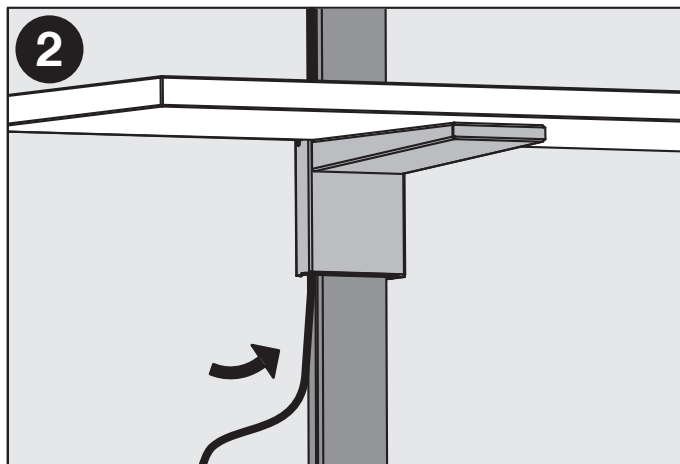
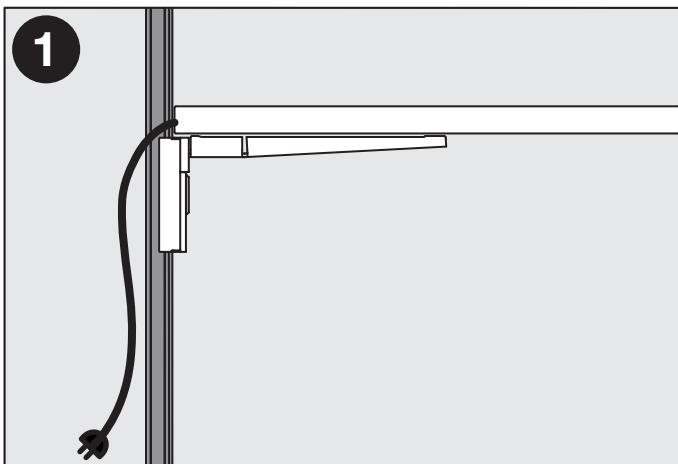
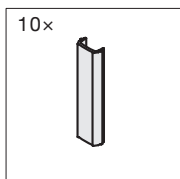



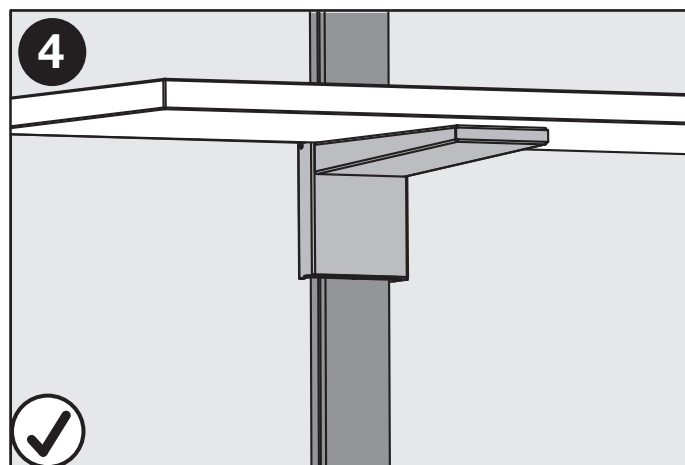
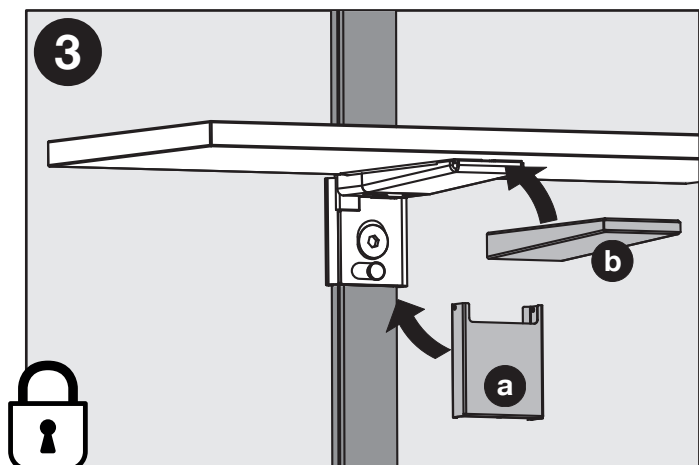
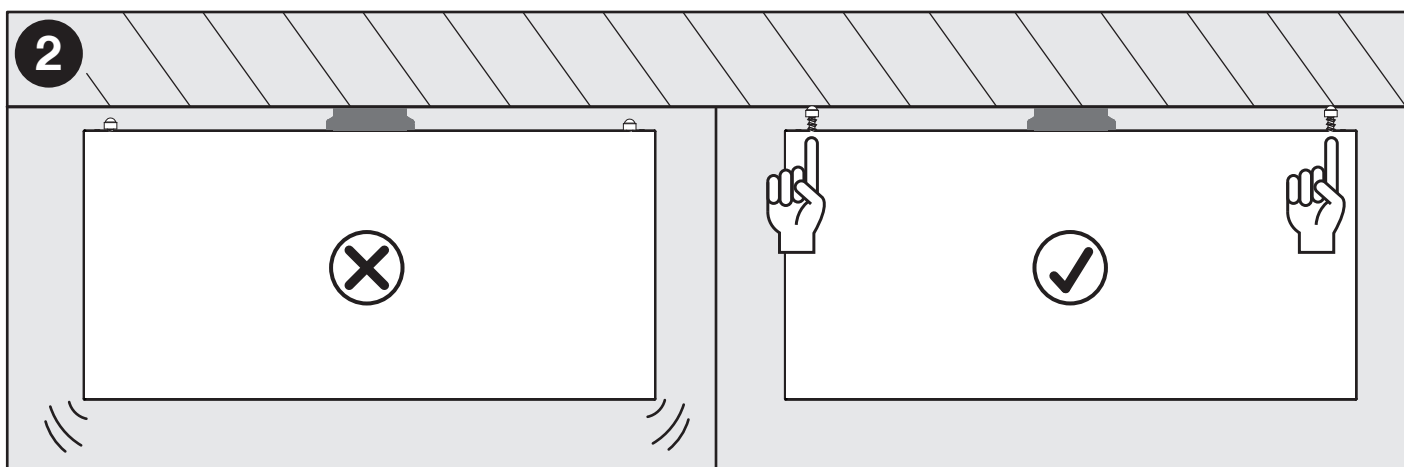
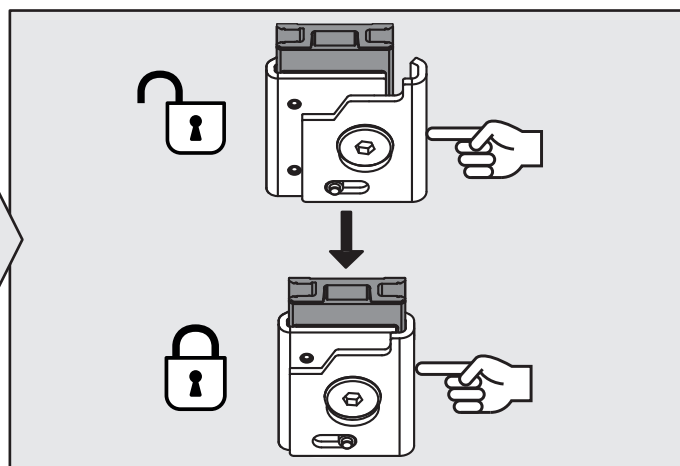
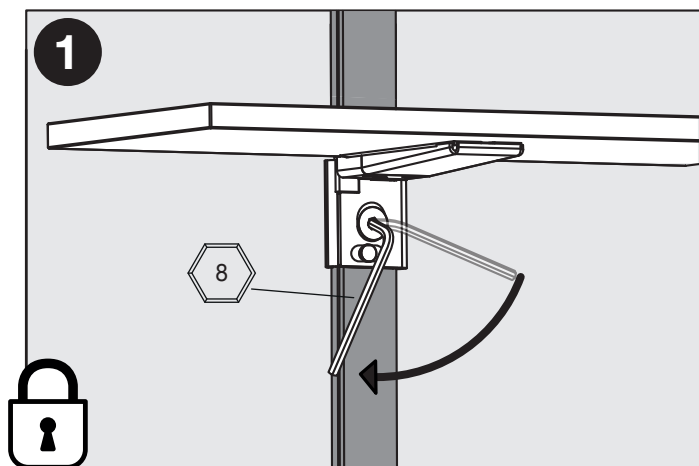
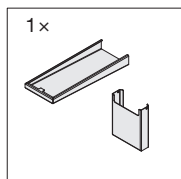

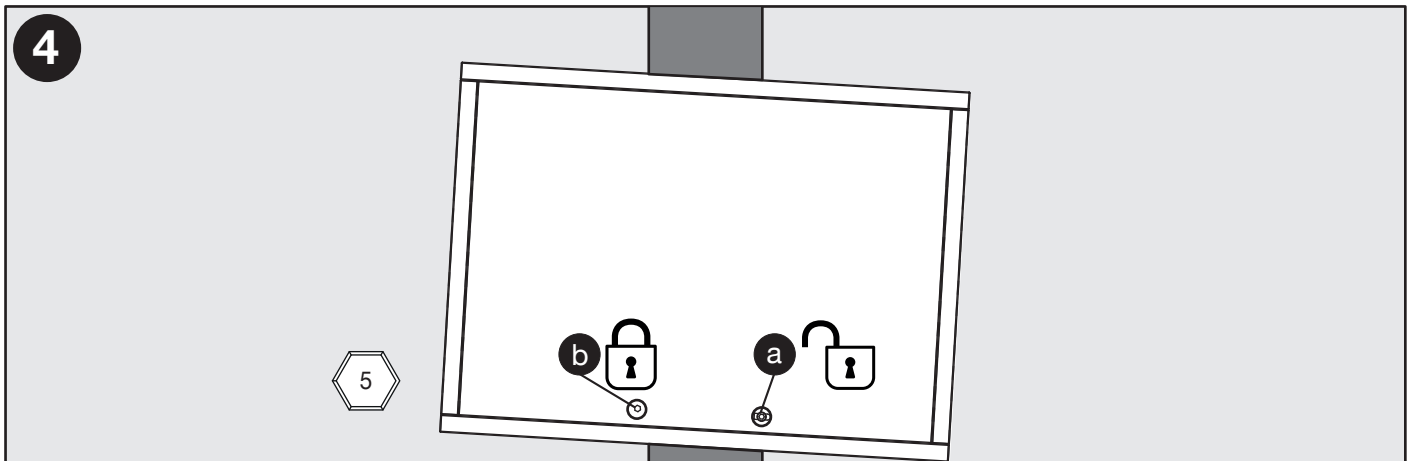
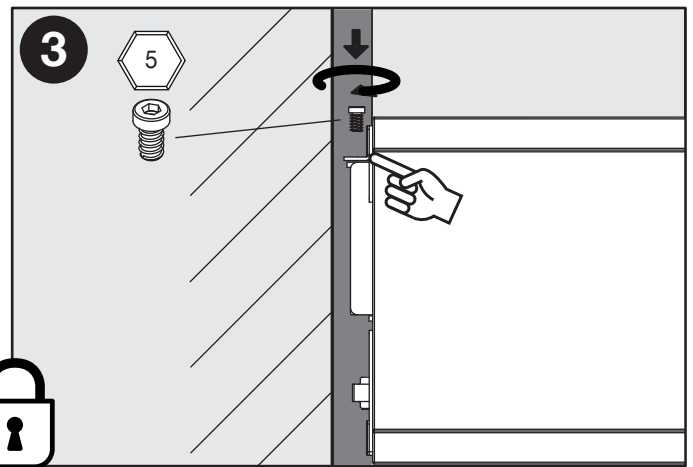
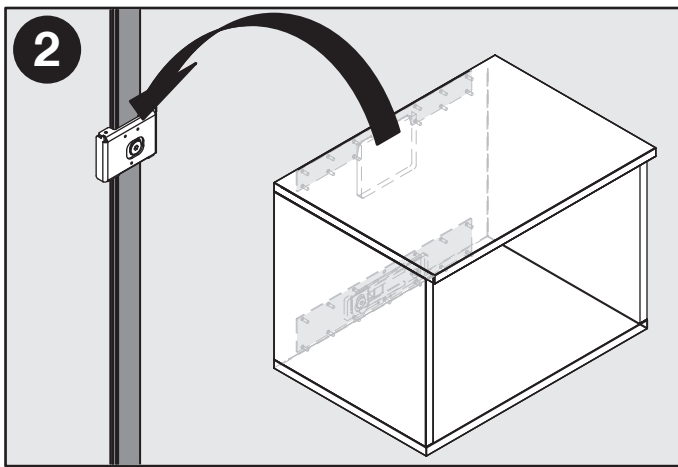
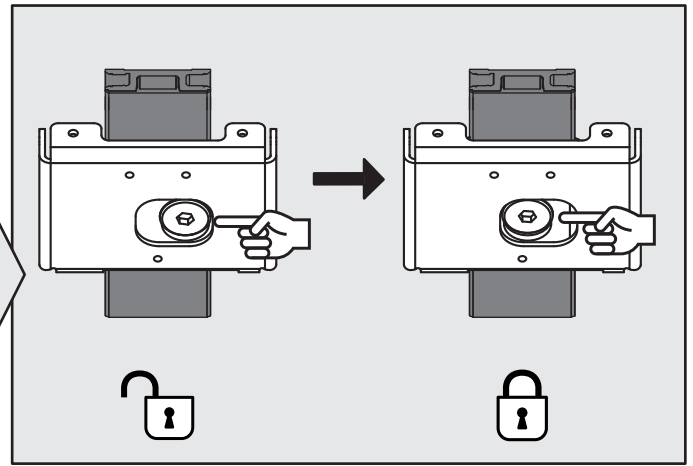
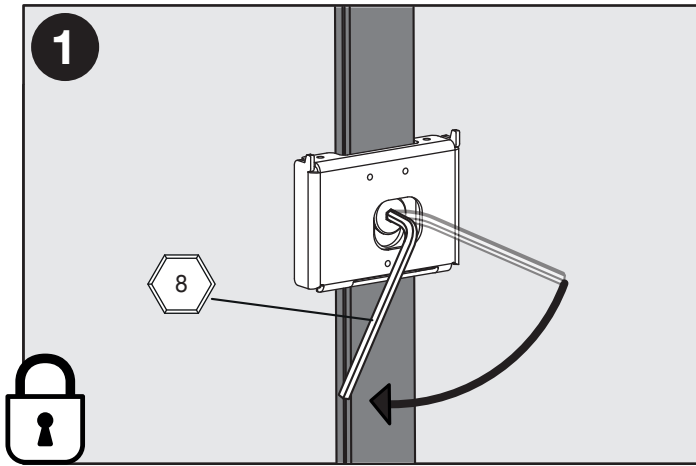
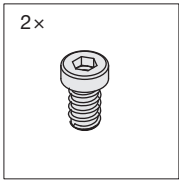

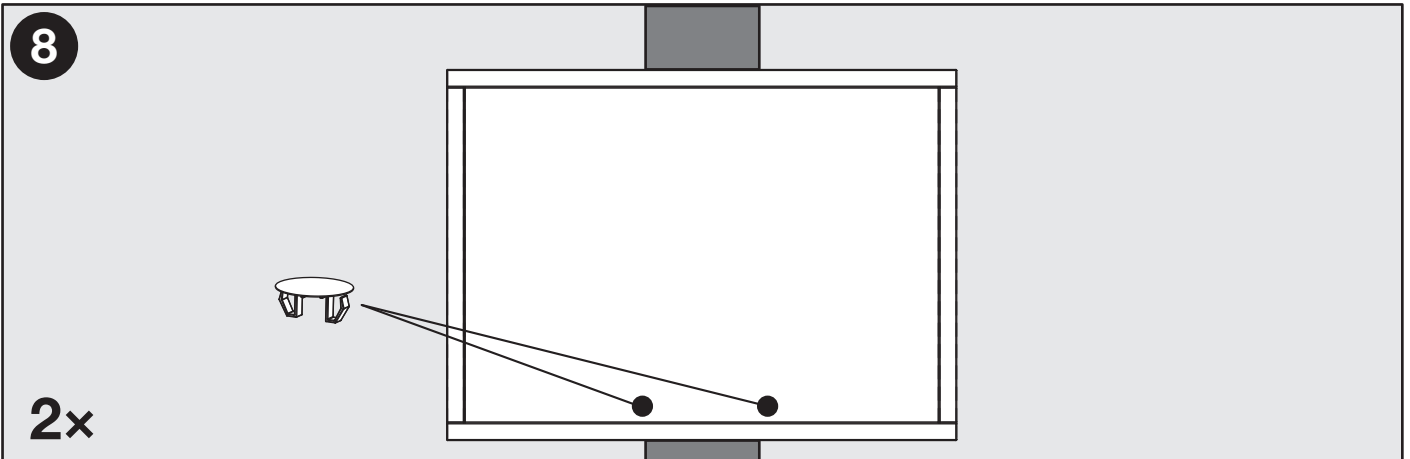
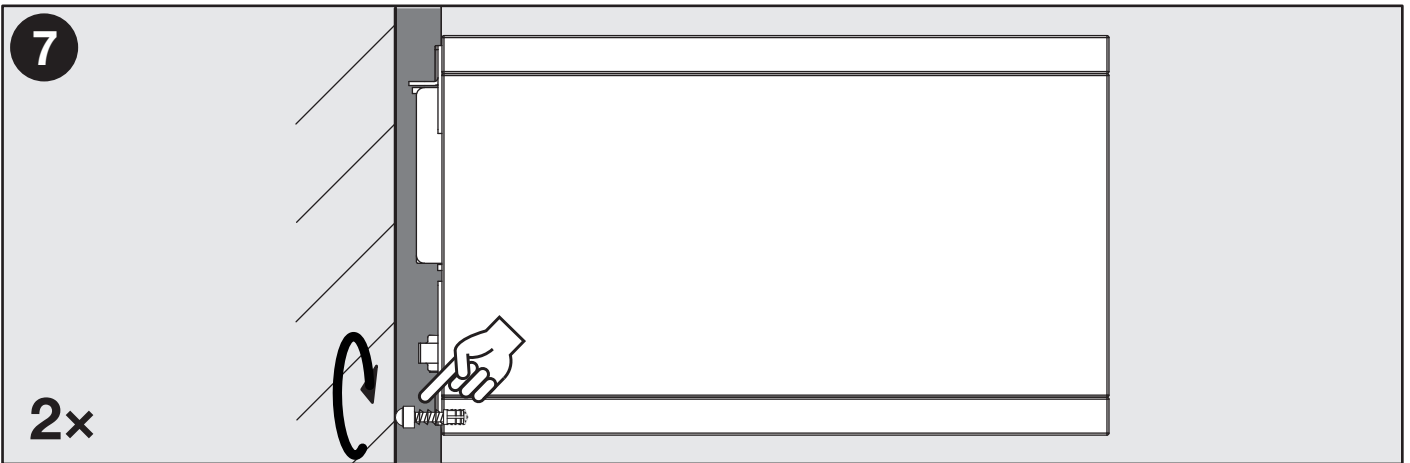
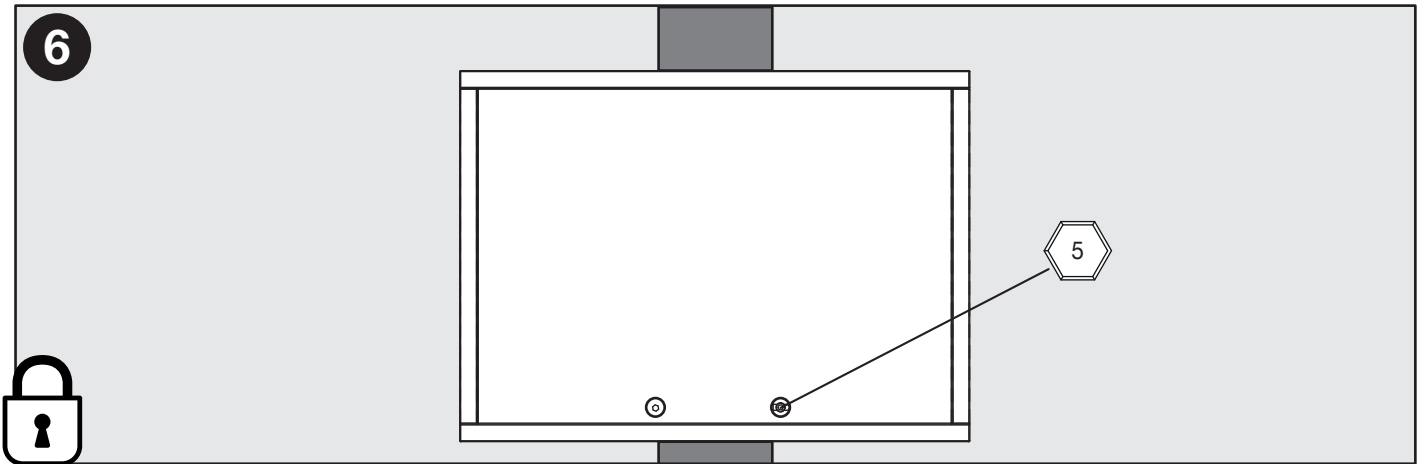
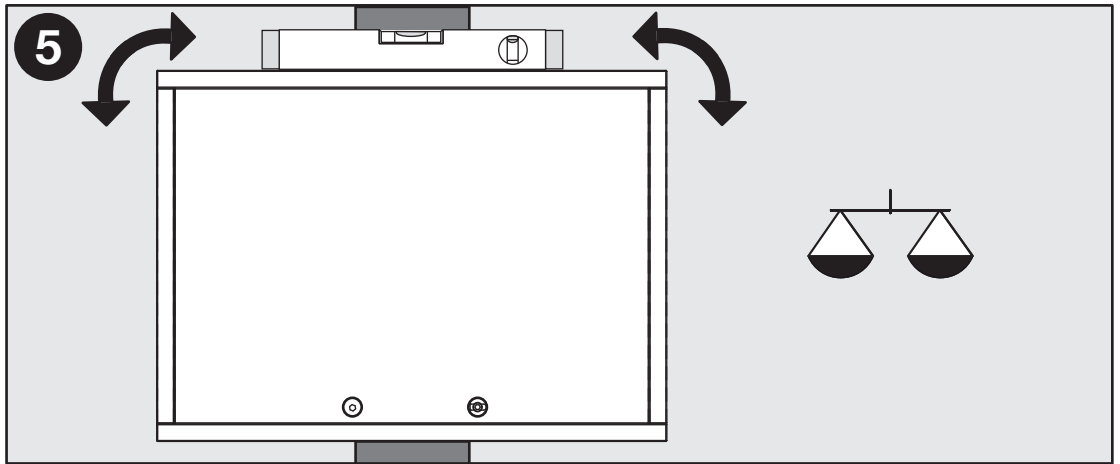
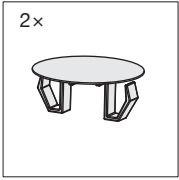

# PECASA KLEIDERSTANGE



Tringle à vêtements Pecasa  
Pecasa clothes rail

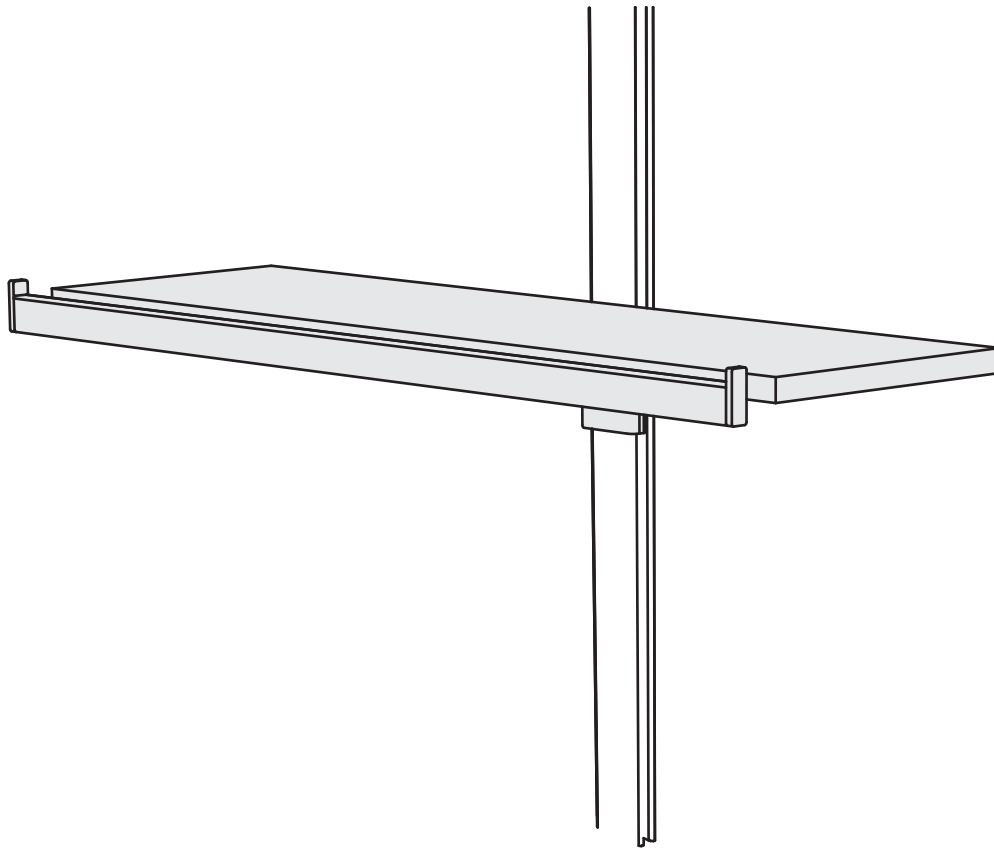

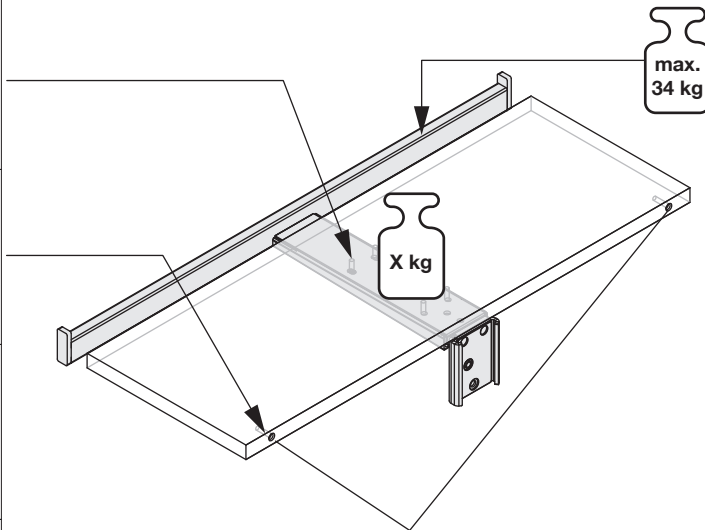
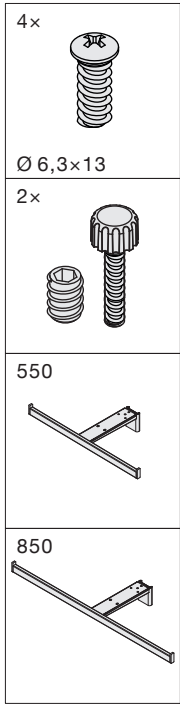

**TOTAL**

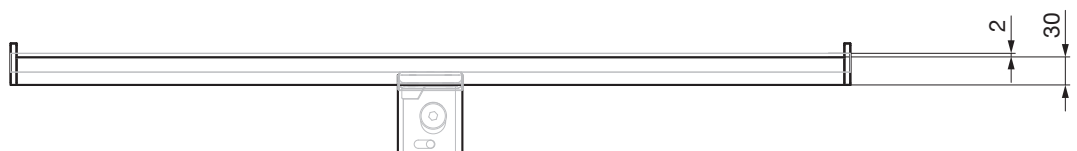
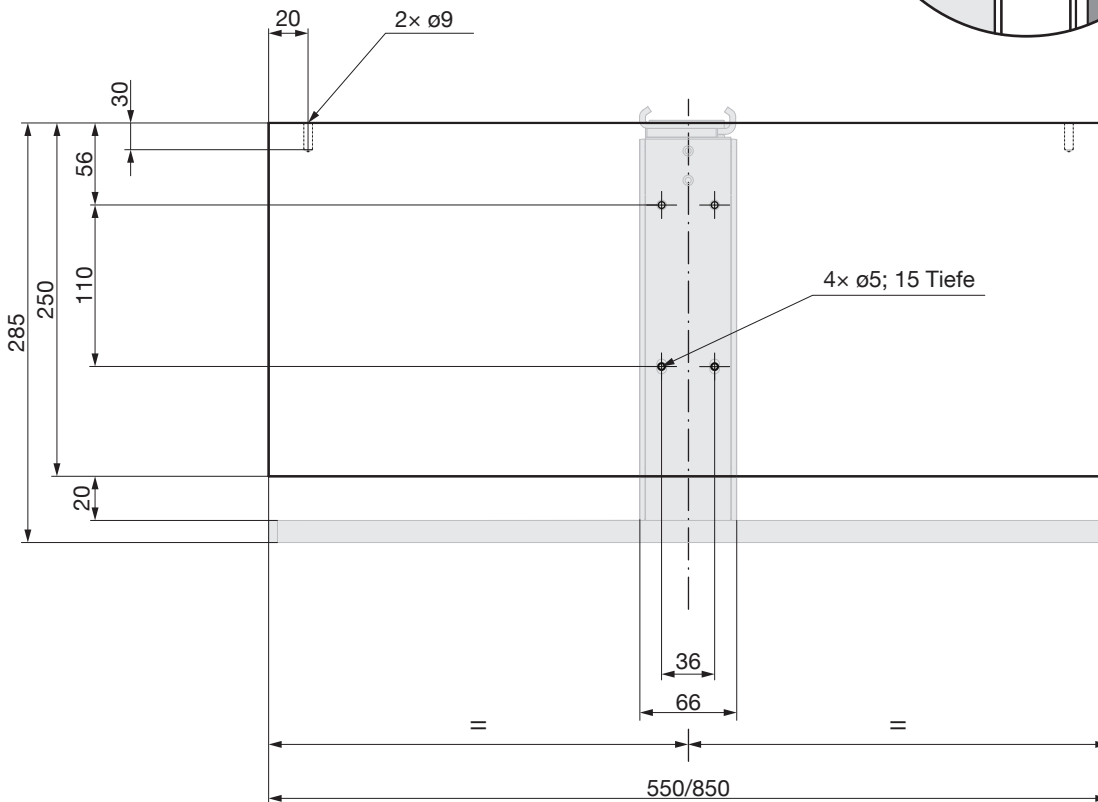
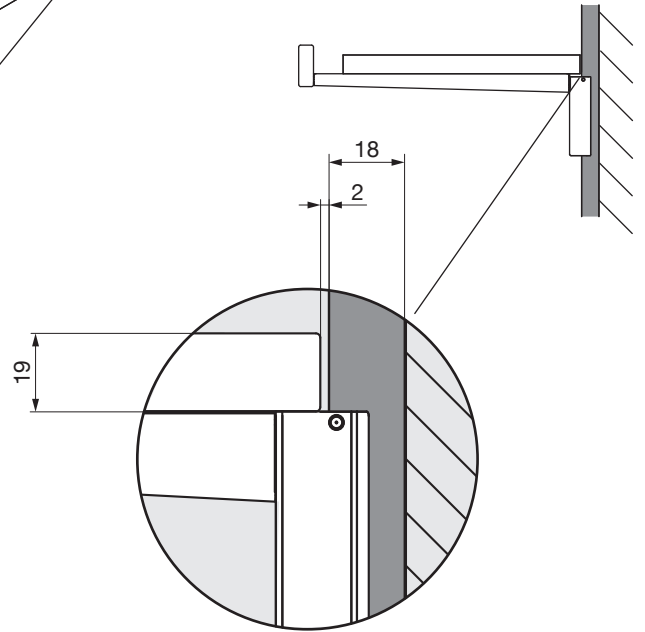
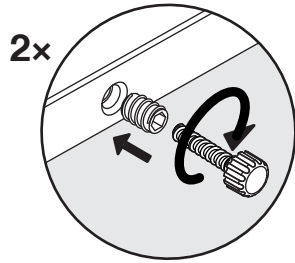
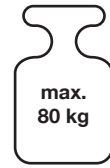

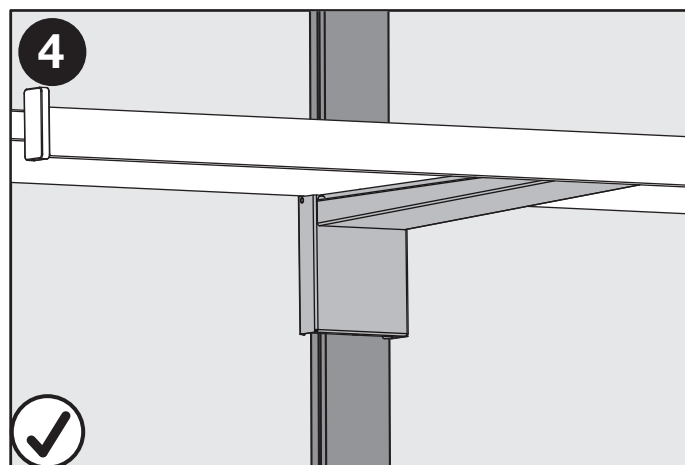
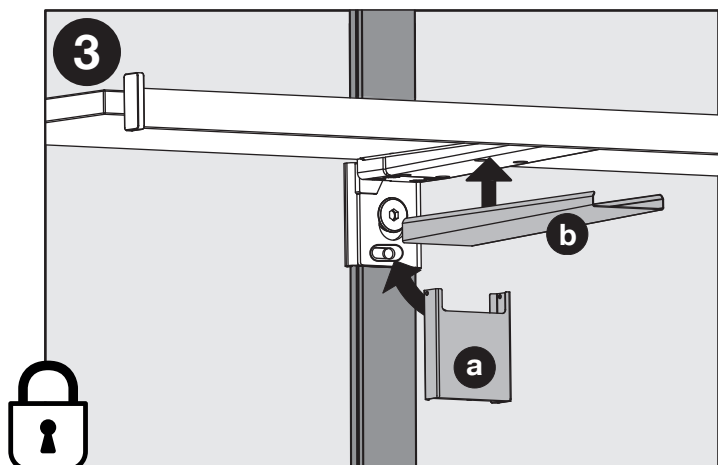
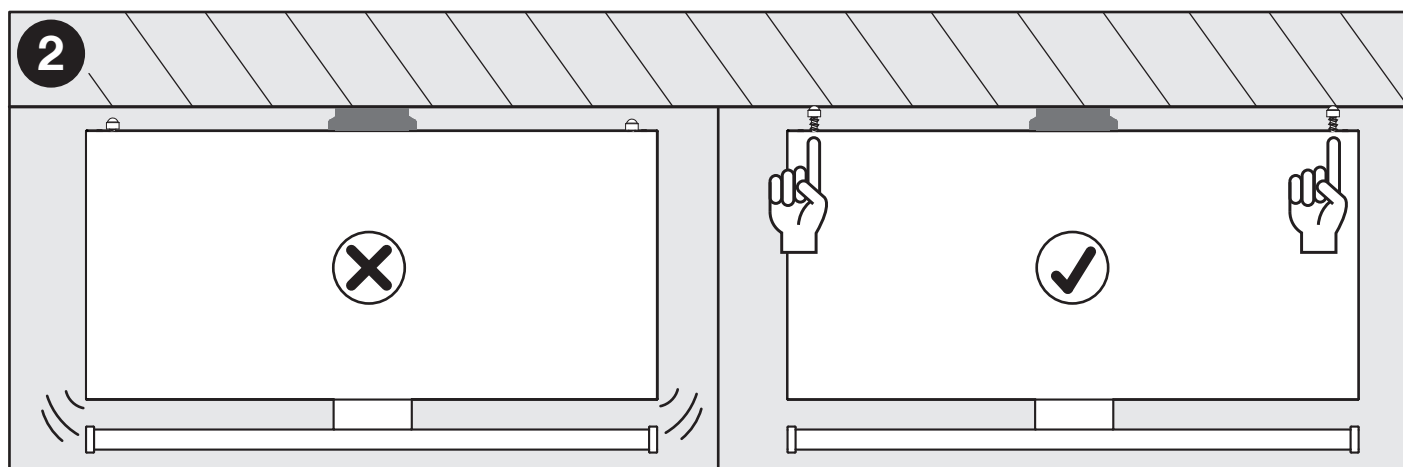
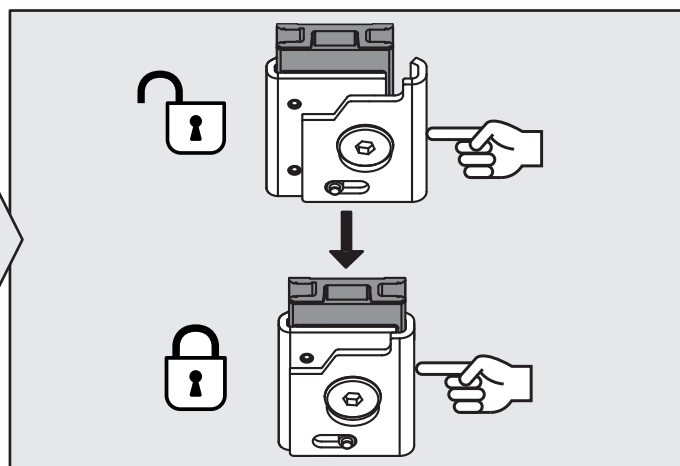
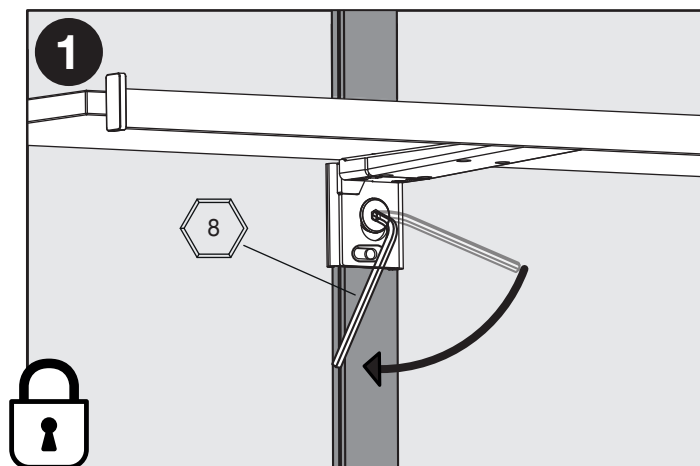

# PECASA UNIVERSALTRÄGER FÜR SPIEGEL, TV



Support universel Pecasa pour miroir, téléviseur  
Pecasa universal bracket for mirrors, TVs

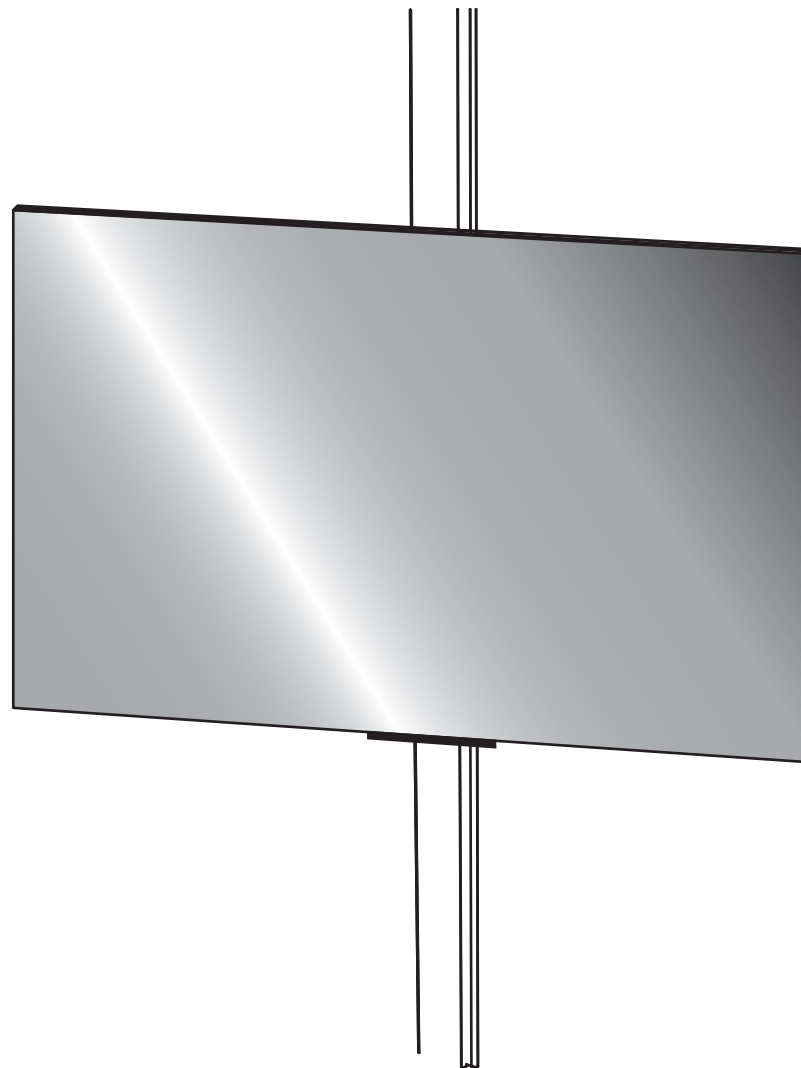

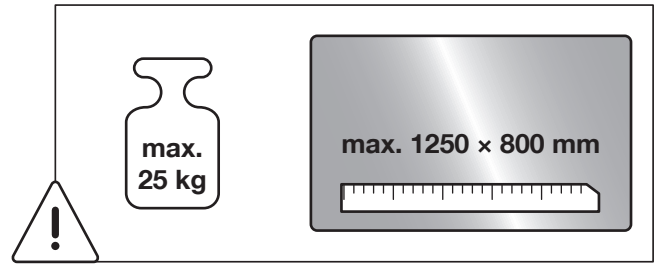
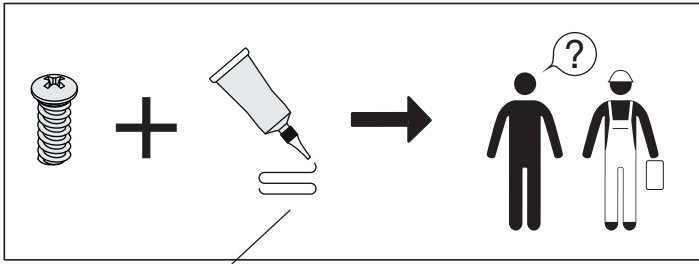

**!**  
Verwendungszweck: Holz  
Utilisation : bois  
Suitable for use with wood

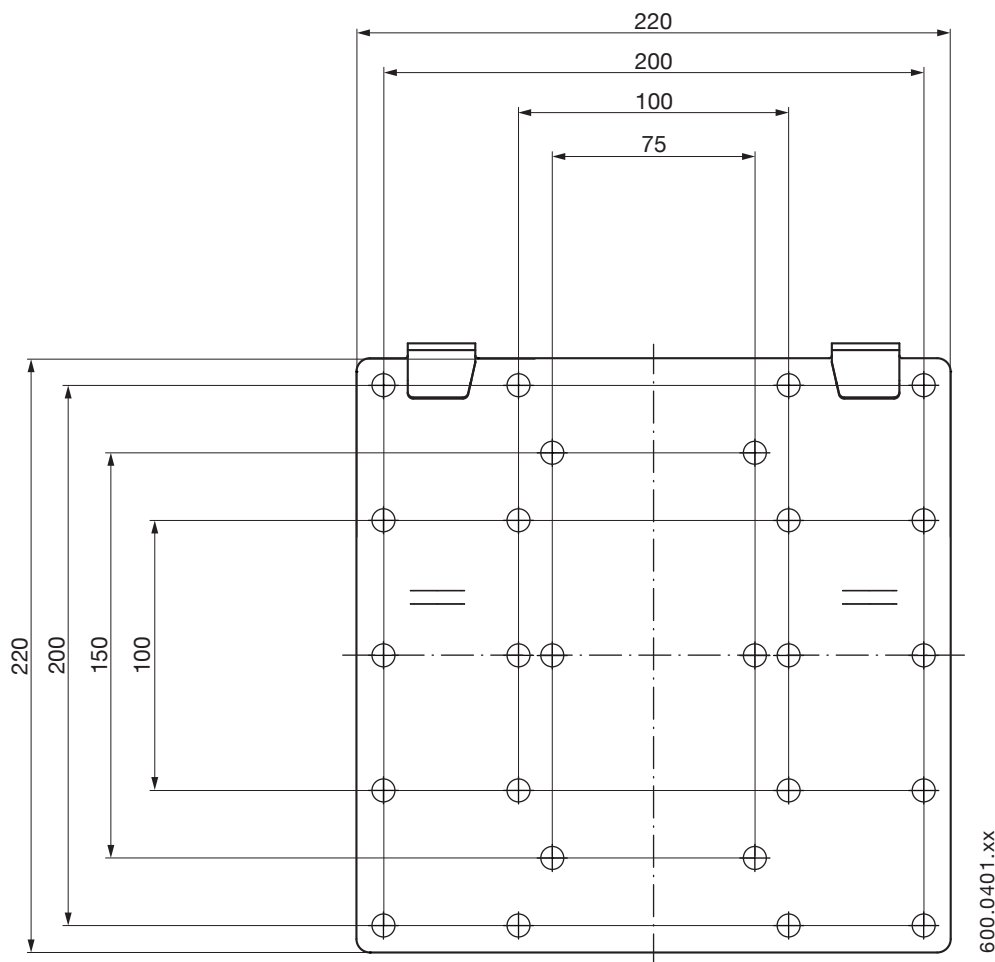



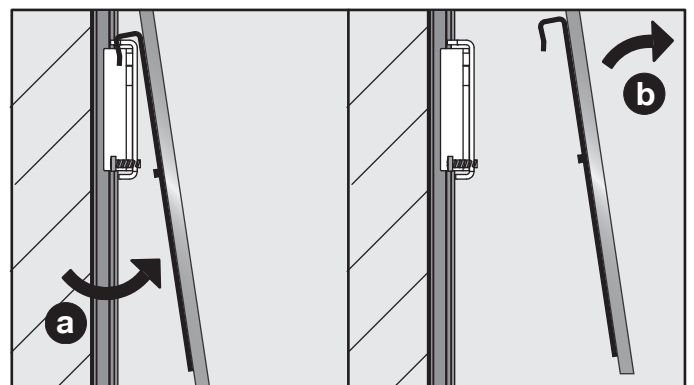
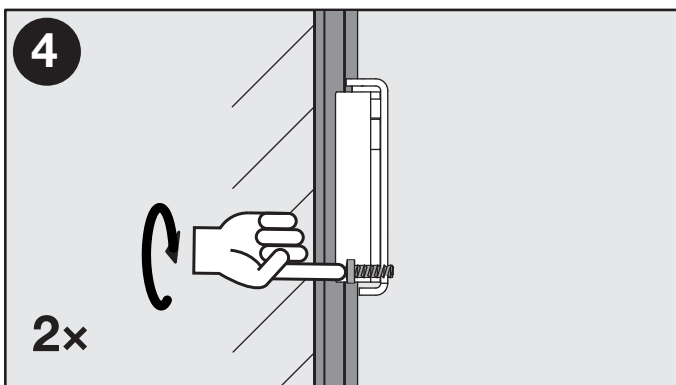
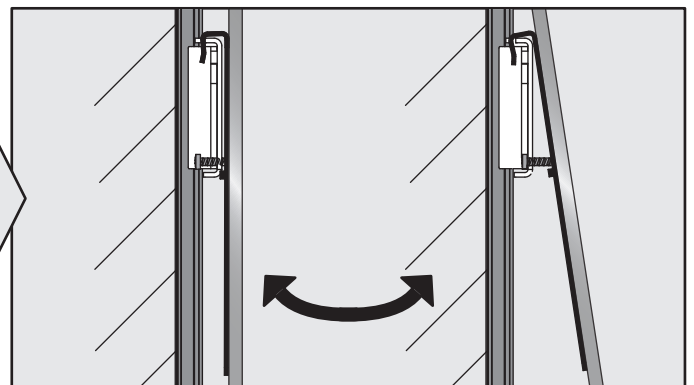
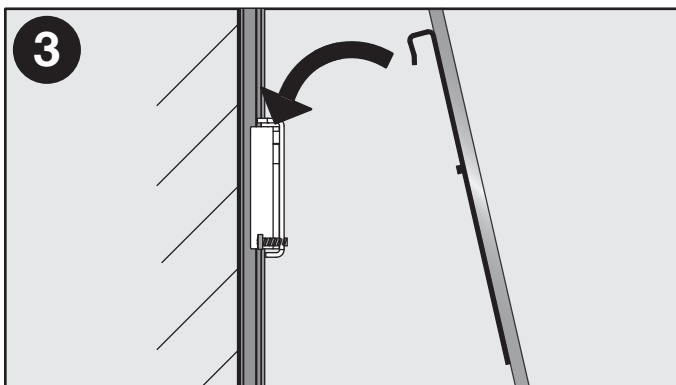
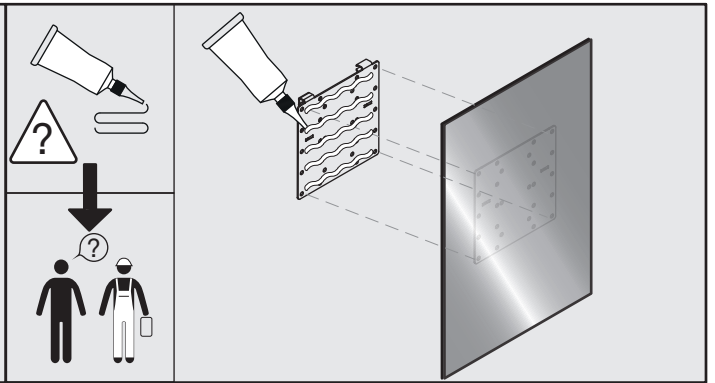
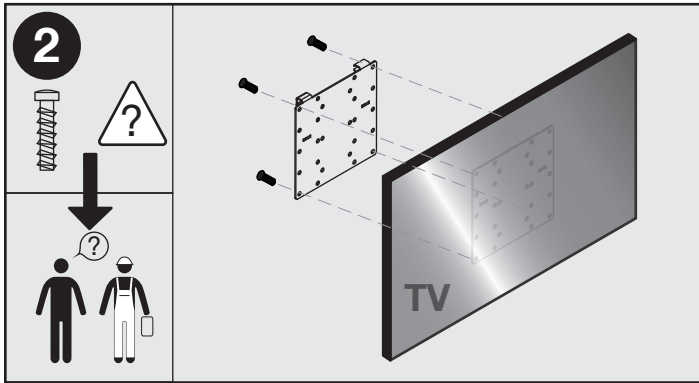
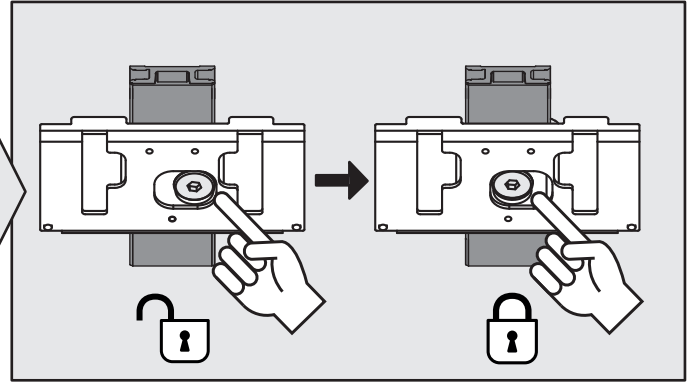
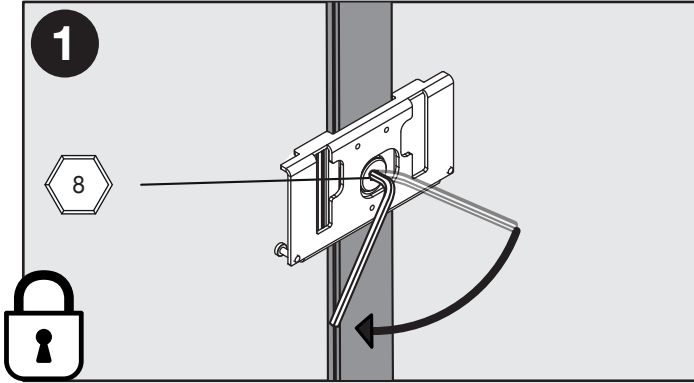
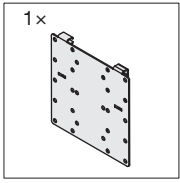

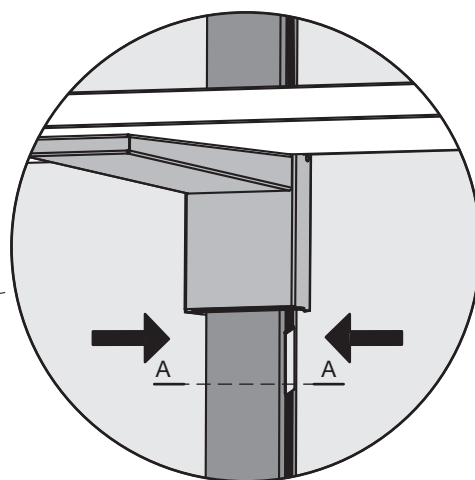
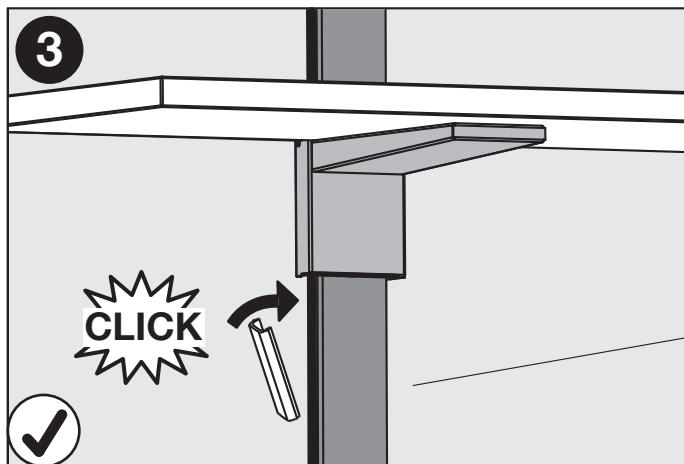
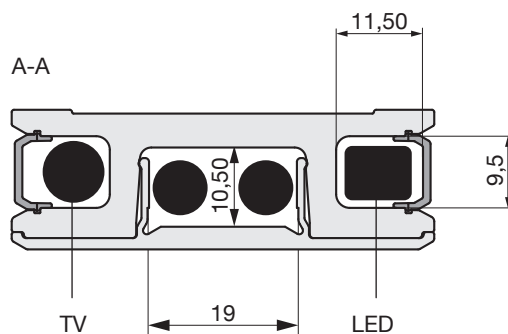
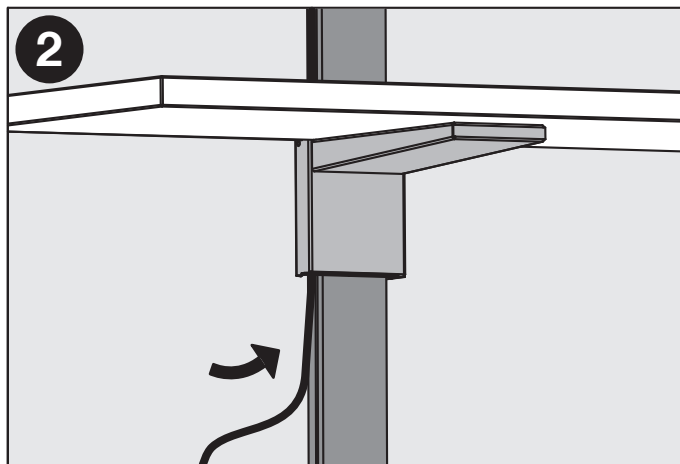
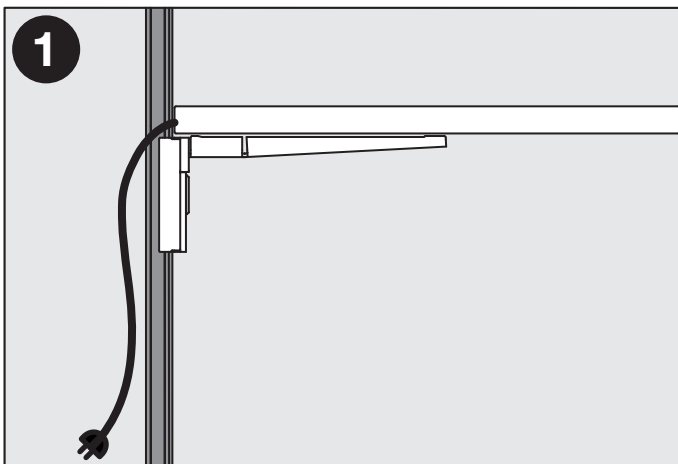
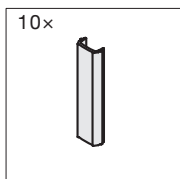

# PECASA ZEITSCHRIFTEN- SCHUHTABLAR

—

Étagère à chaussures / magazines Pecasa  
Pecasa magazine/shoe rack

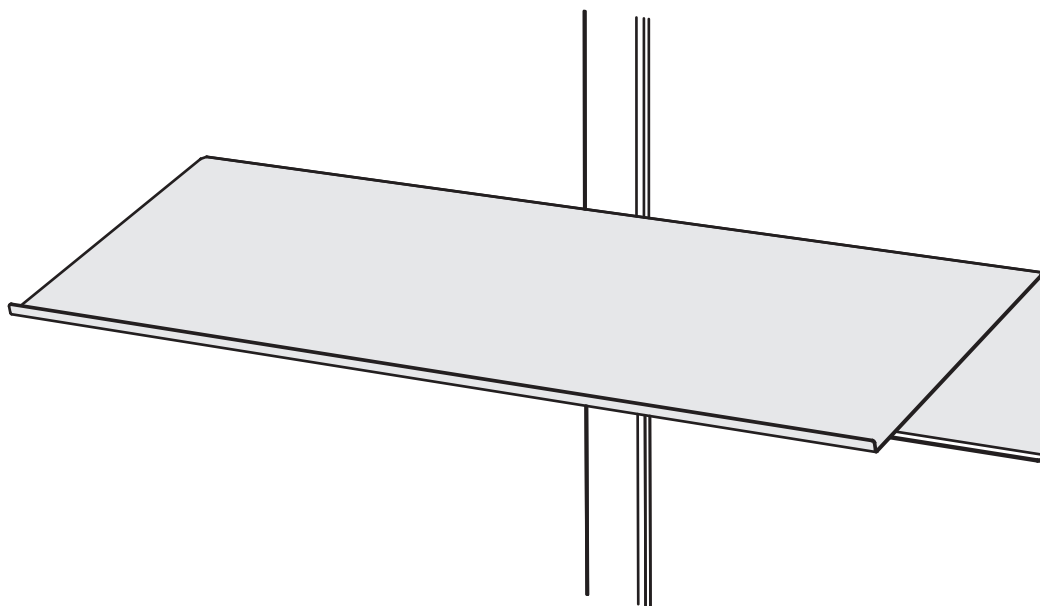

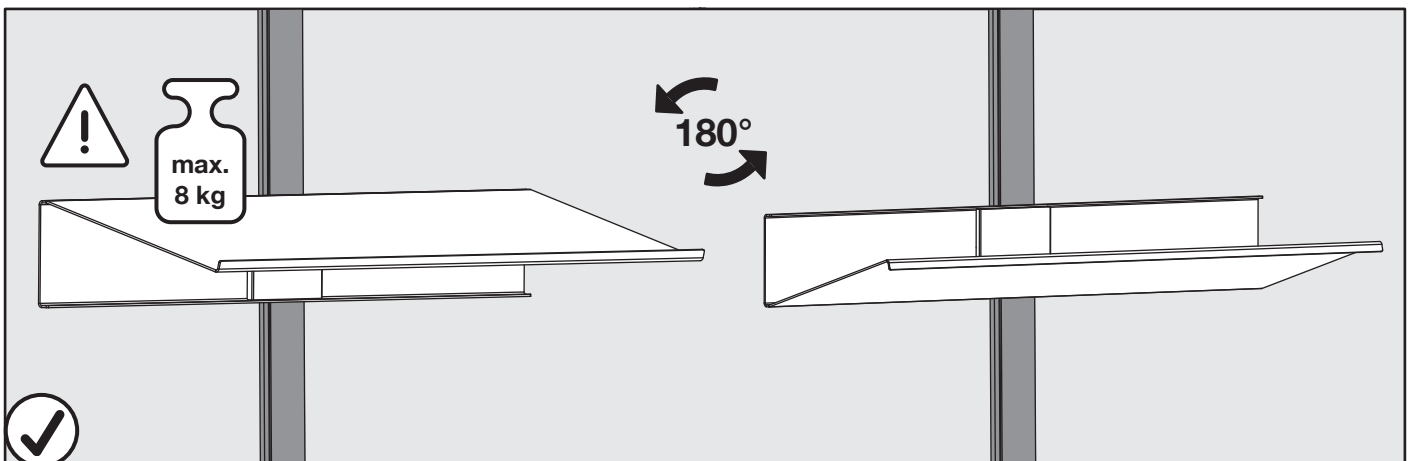
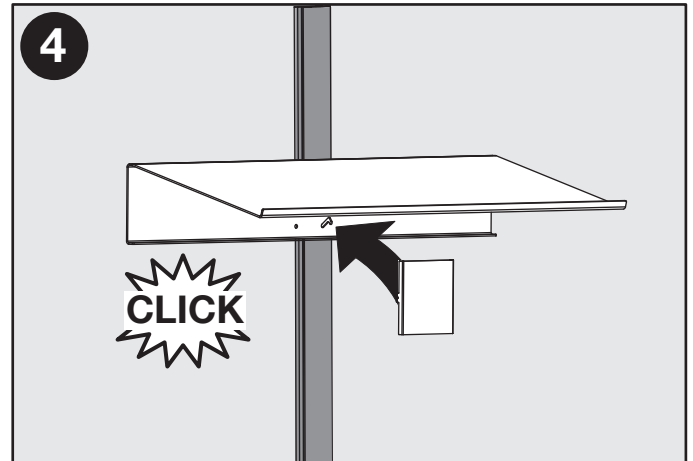
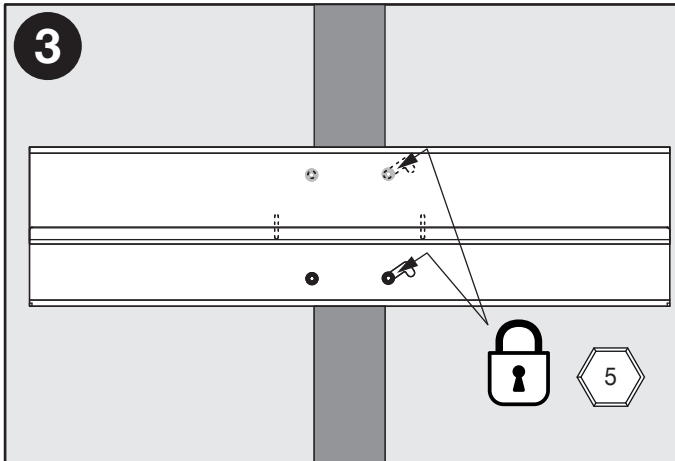
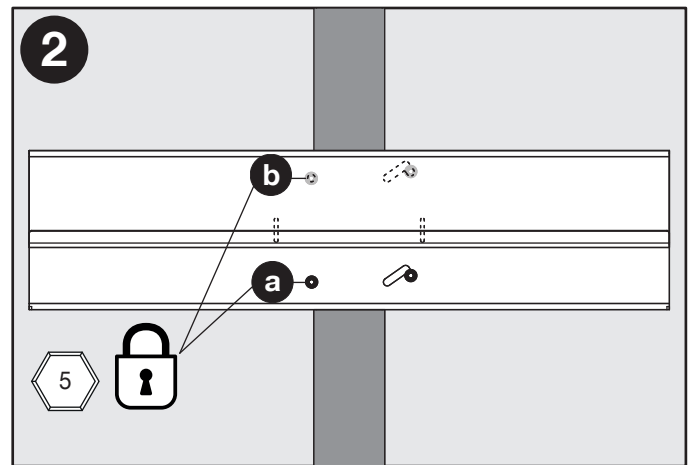
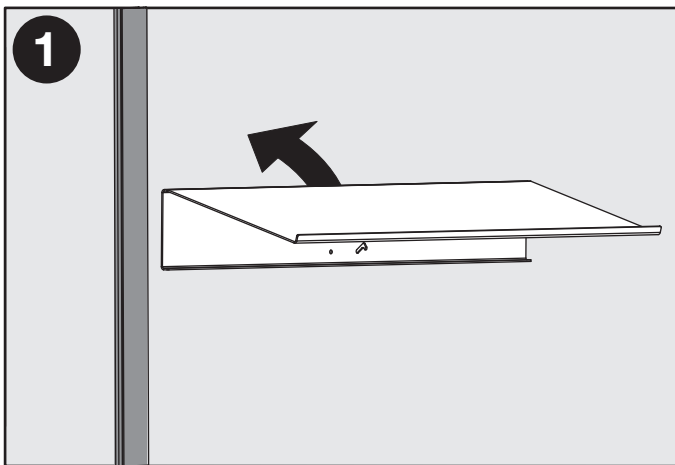
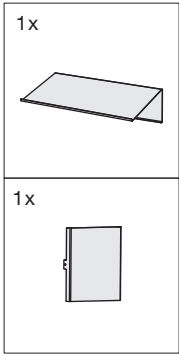

# PECASA HAKENLEISTE

—

Rangée de crochets Pecasa  
Pecasa hook rail

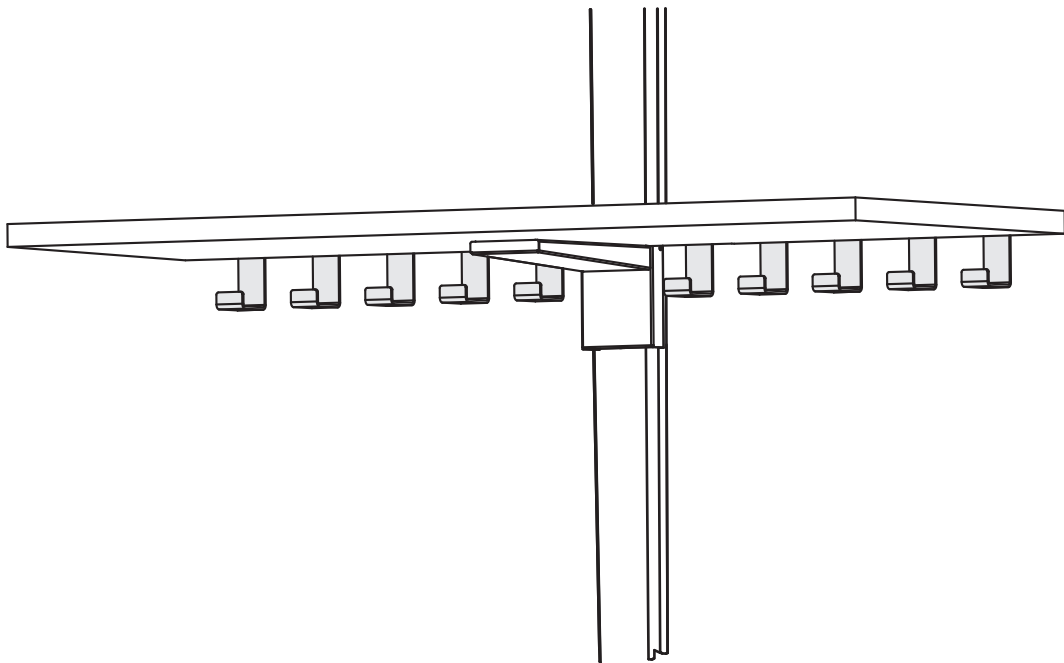

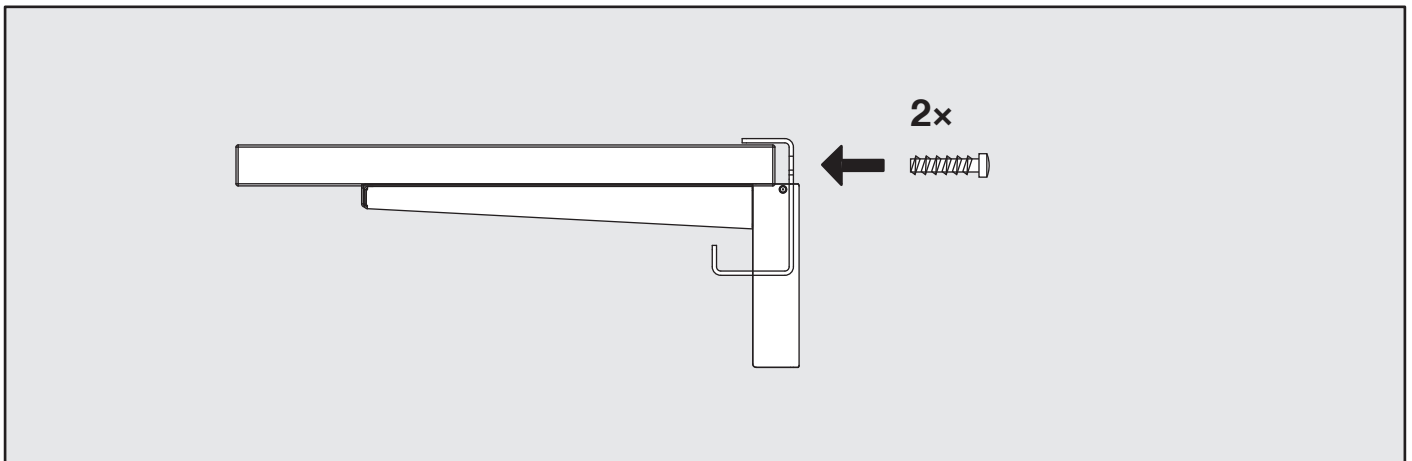
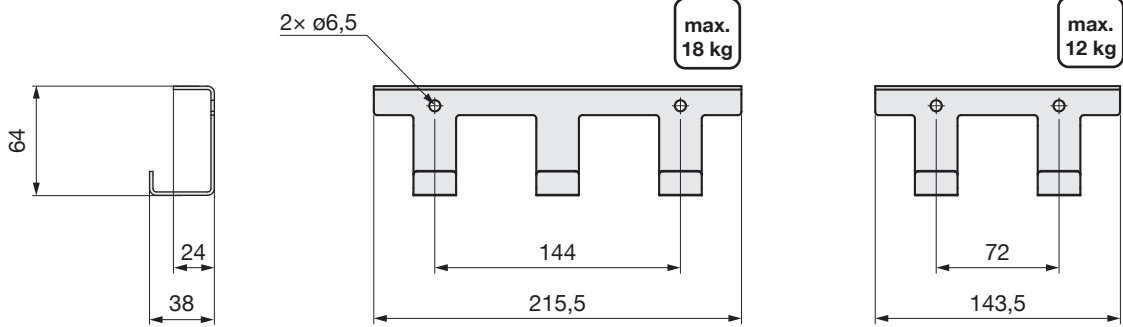
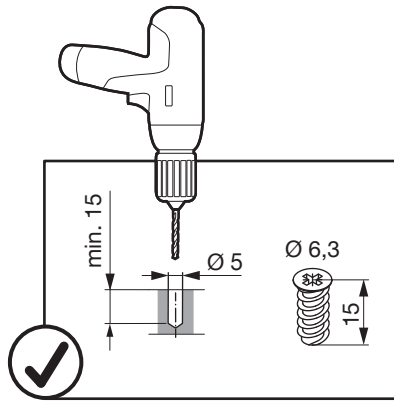
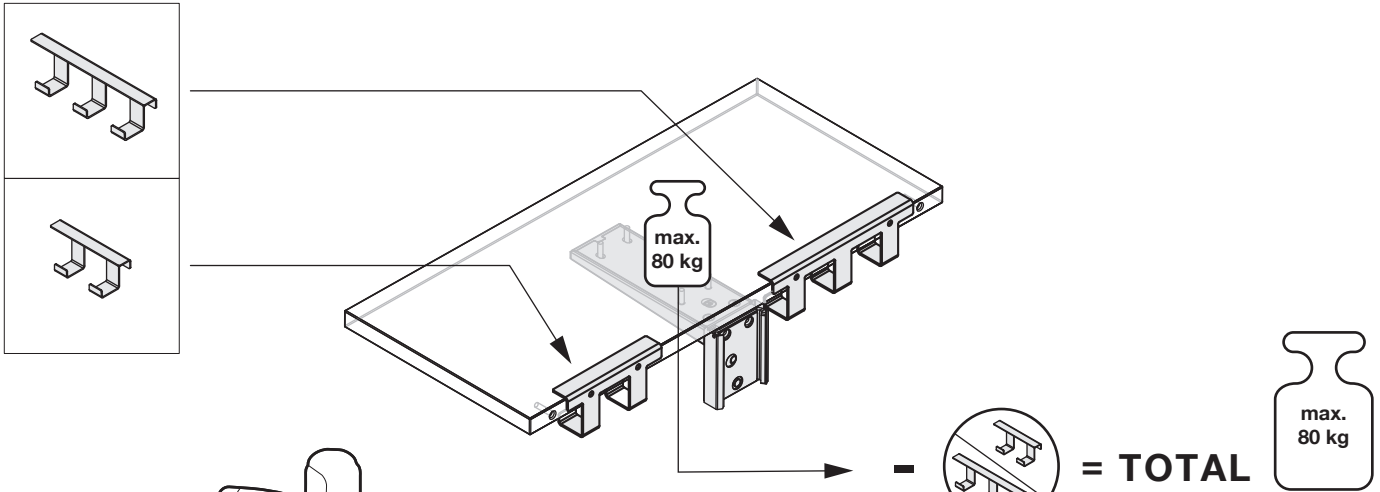

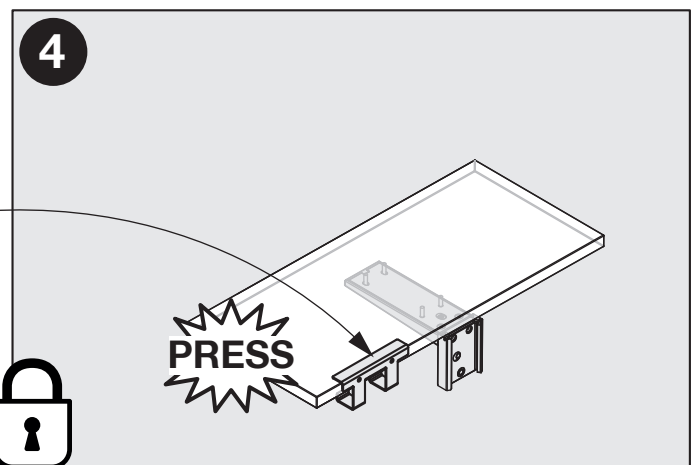
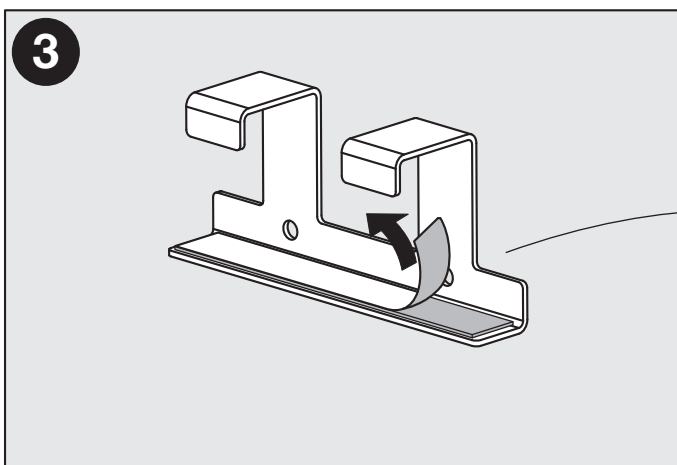
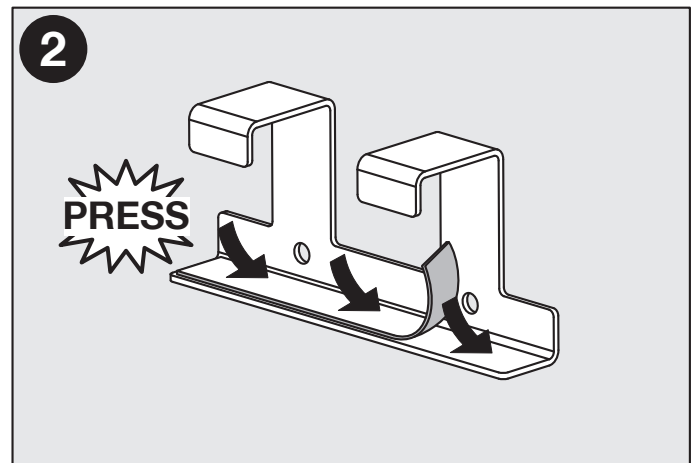
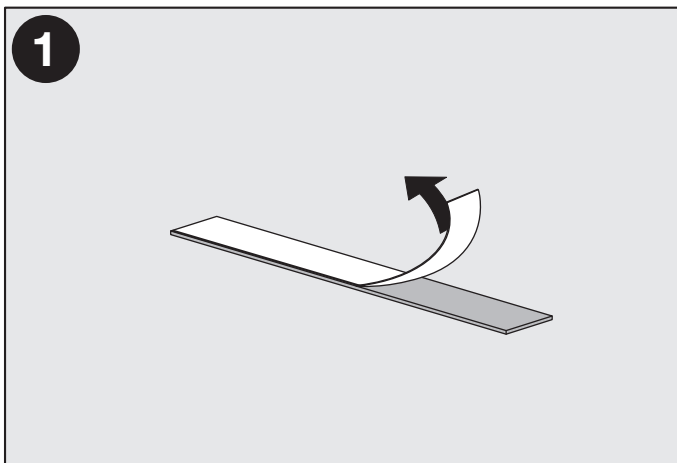
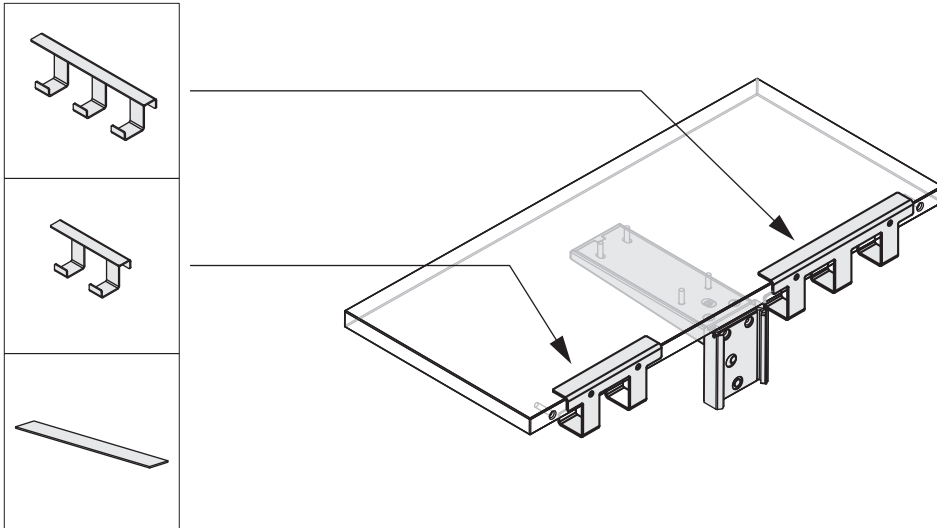

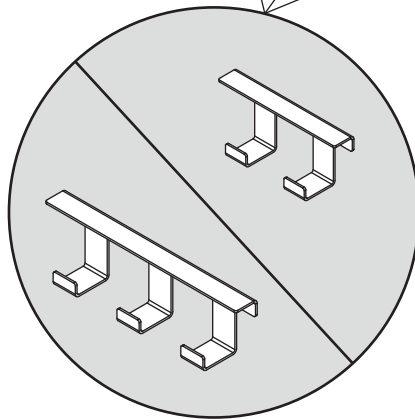
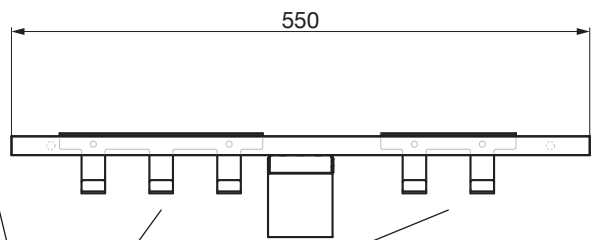
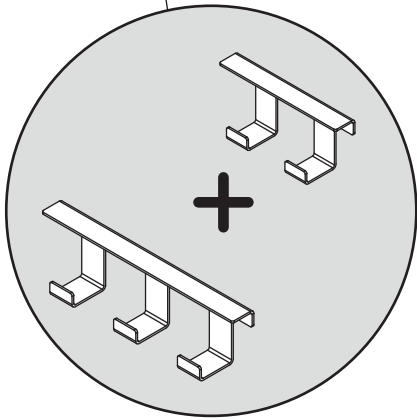
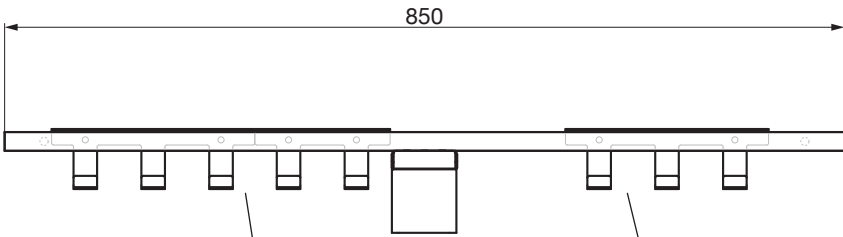



# PECASA HOSENHALTER

—

Porte-pantalons Pecasa  
Pecasa trouser rack

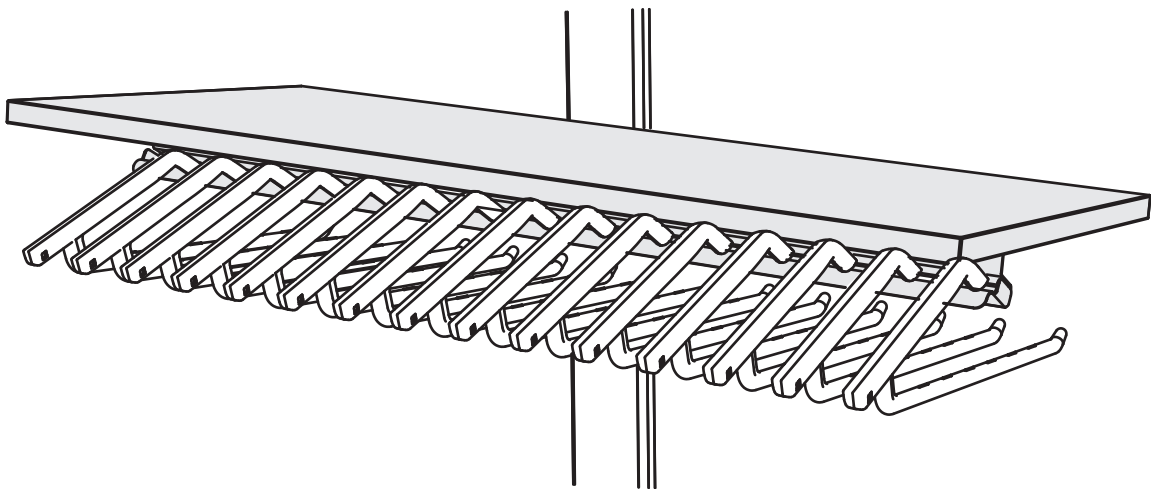

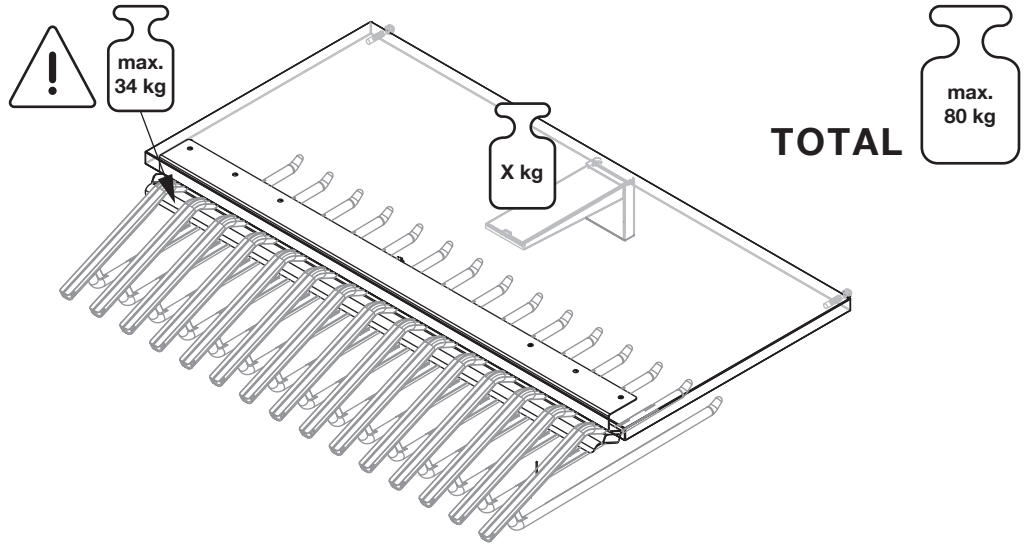
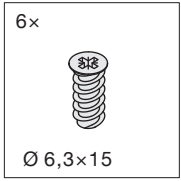

! Montageanleitung  
Instructions de montage  
Installation instructions  
950.0727.MA  
950.0728.MA

550

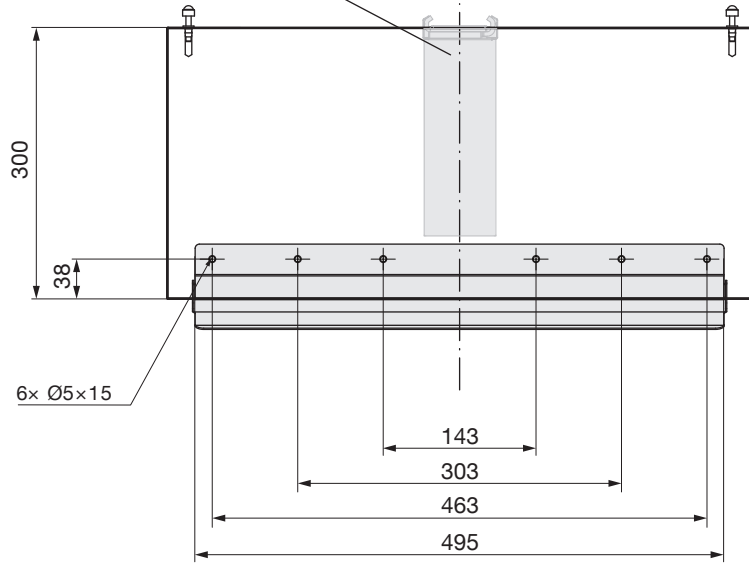

850

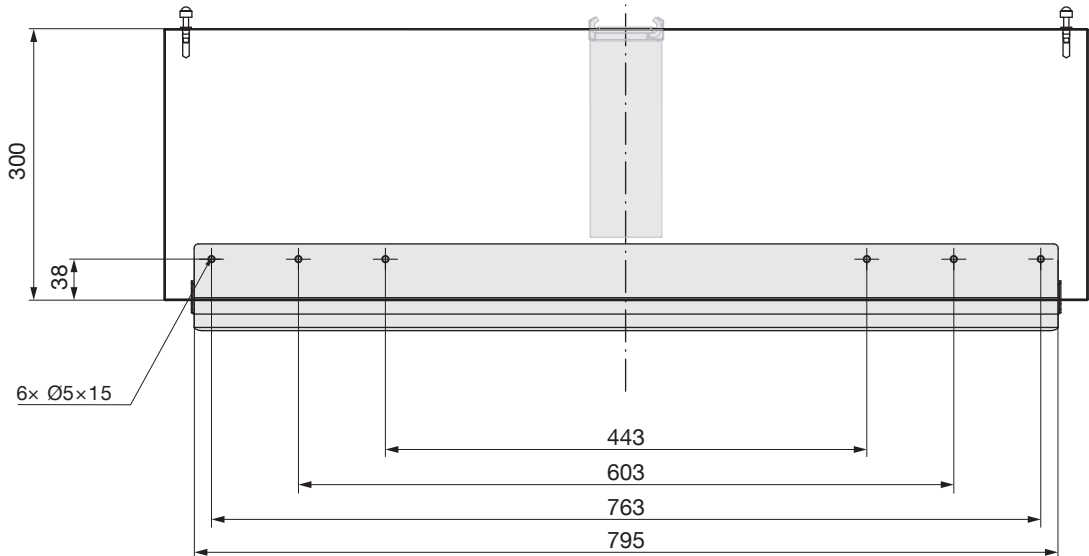

# PECASA ABDECKPROFIL

—  
Profil de recouvrement Pecasa  
Pecasa cover profile

