

PLENO PLUS FIORO

Hochschrankauszug für Möbel mit scharnierten Türen
 Système pour armoires hautes pour meubles dotés de portes à charnières
 Larder pull-out for furniture with hinged doors

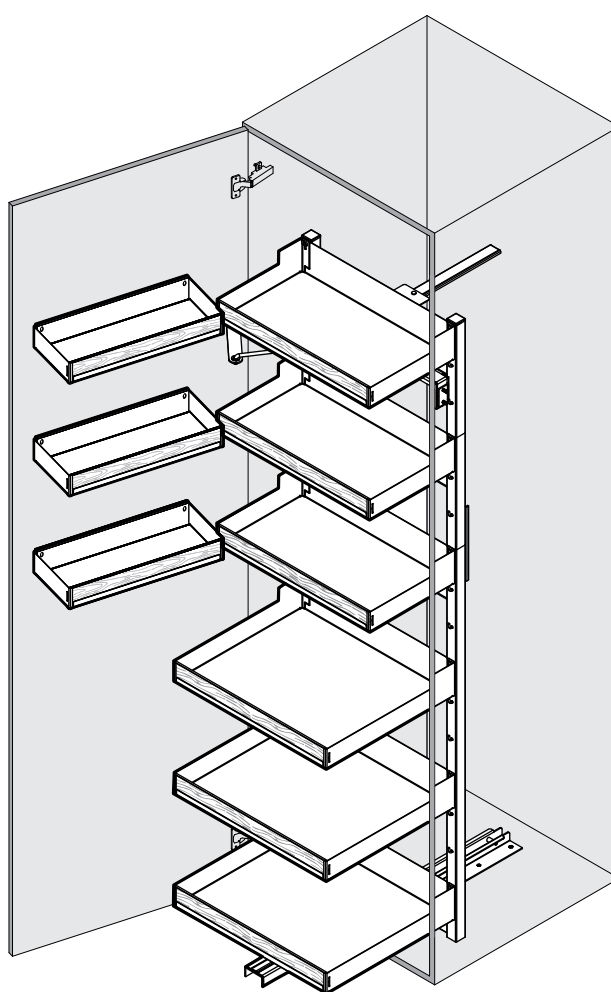

Art.Nr.

1300 mm



100.1133.xx





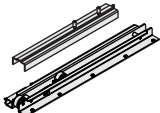
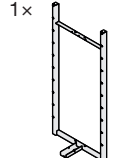
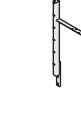
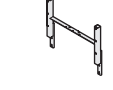
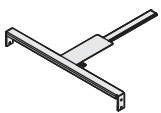
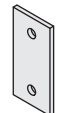
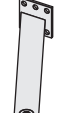
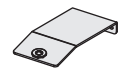
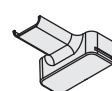
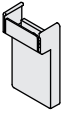
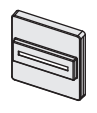

1600 mm

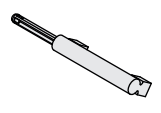
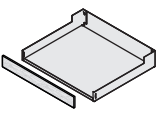
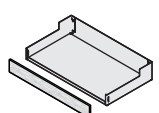
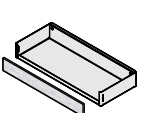
100.1131.xx

1900 mm

100.1003.xx

1x 	1x 	1x  100.1002.xx	1x  100.1003.xx	1x 	2x 	1x 	1x 
1x 	2x 	1x 	2x 	1x 	2-3x 	2-3x 	2-3x 

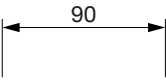
	Symbole	Symboles	Symbols
	Warnung	Avertissement	Warning
	Korrekt	Correct	Correct
	Nicht korrekt	Incorrect	Incorrect
	Lösen/gelöst	Détacher/détaché	Release/Released
	Fixieren/fixiert	Fixer/fixé	Secure/Secured
	Klick-Geräusch beim Einrasten	«Clic» lors de l'encliquetage	Audible click on engagement
	Alle Masse in mm	Toutes les dimensions en mm	All dimensions in mm



DE Die Gewichts- und Beladungsangaben gelten als Maximalwert und sind abhängig von den gewählten Schrankmaterialien (ein verwindungsteifes Material - z.B. Massivholz, Spanplatten - ist zu wählen) und der Schrankkonstruktion und können dementsprechend variieren! Es wird davon ausgegangen, dass geeignete Verbindungs- und ggf. Konstruktionshilfsmittel (z.B. Stützen) eingesetzt werden. Eine verbindliche Beladungsangabe obliegt dem Verarbeiter!

Die technischen Darstellungen und Massangaben - auch Abbildungen und Zeichnungen - sind unverbindlich. Konstruktionsverbesserungen sind vorbehalten!

FR Les indications relatives au poids et à la charge servent de valeurs maximales, dépendent des matériaux choisis pour l'armoire et sa structure (choisir un matériau résistant à la torsion, p. ex. bois massif, panneau d'agglomérés), et peuvent varier en conséquence ! On suppose que des éléments de liaison et de structure appropriés (p.ex. des supports) sont utilisés. Le responsable de la transformation du meuble est tenu de définir lui-même les valeurs de la charge !

Les illustrations technique et les cotes - y compris sur les schémas et les dessins - sont non contractuelles. Sous réserve d'améliorations de la construction !

EN The weight and load specifications are given as maximum values and depend on the selected cupboard materials (a warp resistant material, such as solid wood or chipboard, should be chosen) and cupboard design so they may vary accordingly! It is assumed that suitable fasteners and, if required, construction hardware (e.g. supports) will be used. The fabricator is responsible for binding load specifications!

Technical information and stated dimensions (including in illustrations and drawings) must not be regarded as binding. Design subject to change without notice (in interest of improvement)!

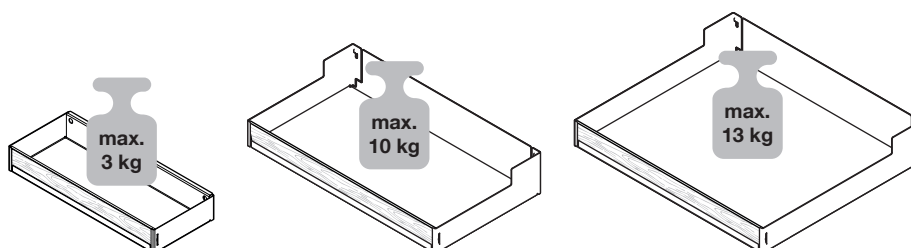

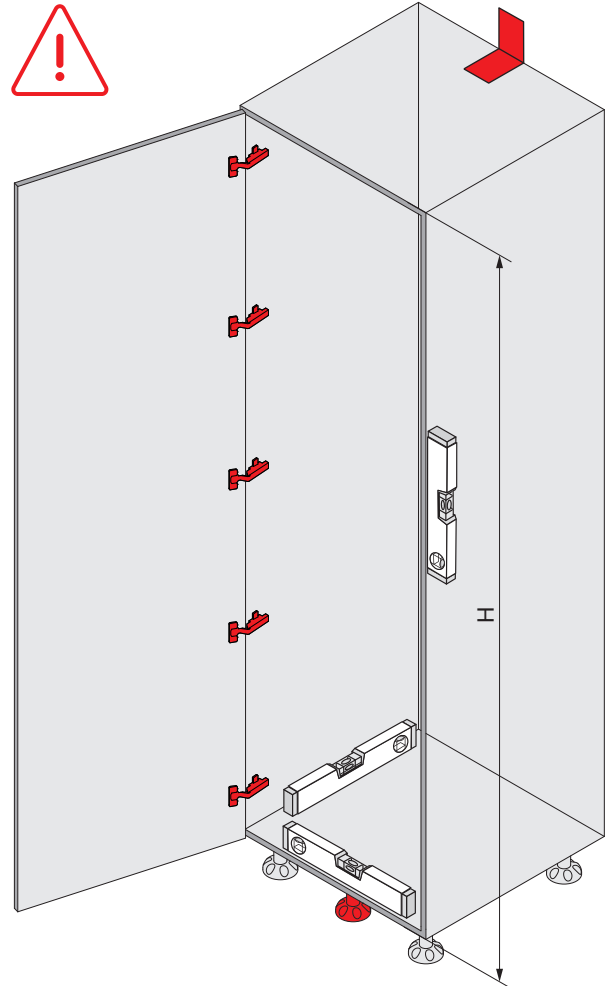
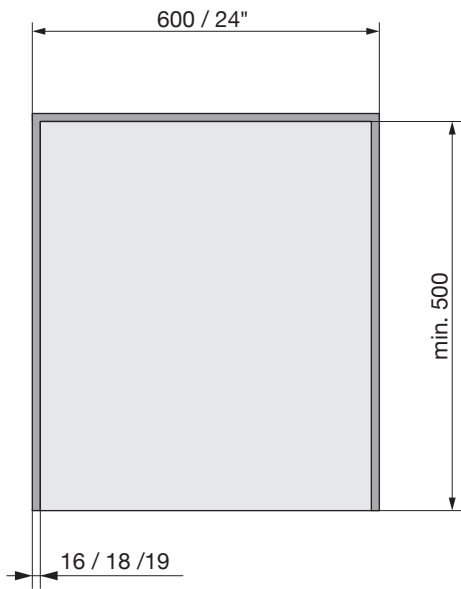

H						
1300	2x	2x	3x		max. 8 kg	
1600	3x	2x	4x		max. 8 kg	
1900	3x	3x	5x		max. 12 kg	

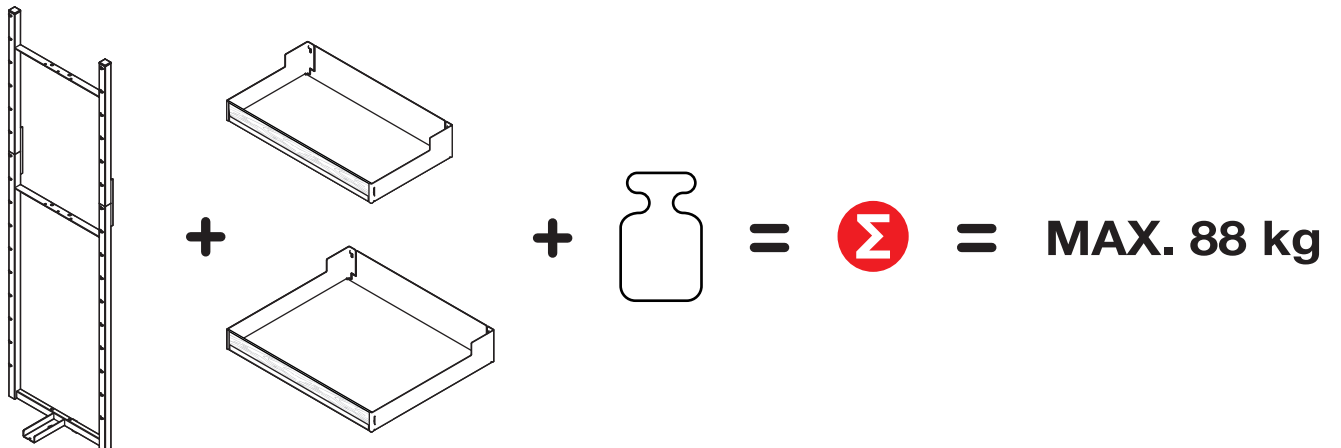

1

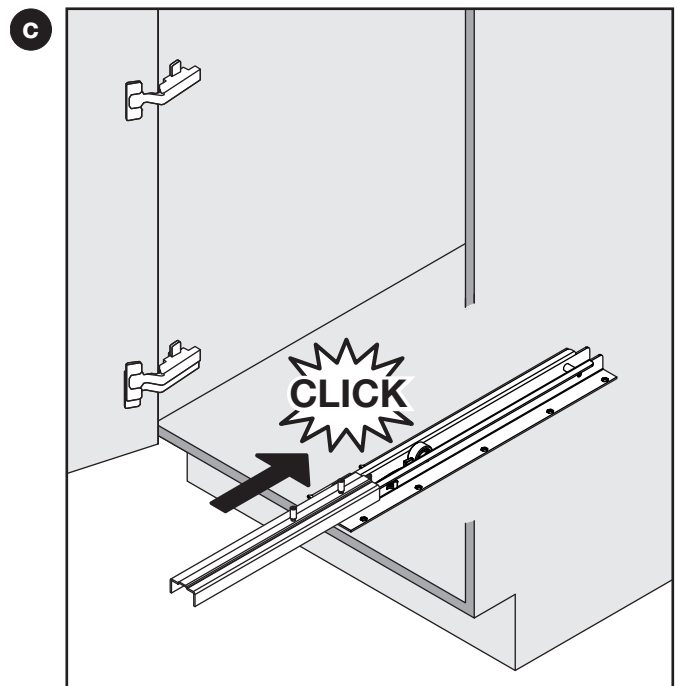
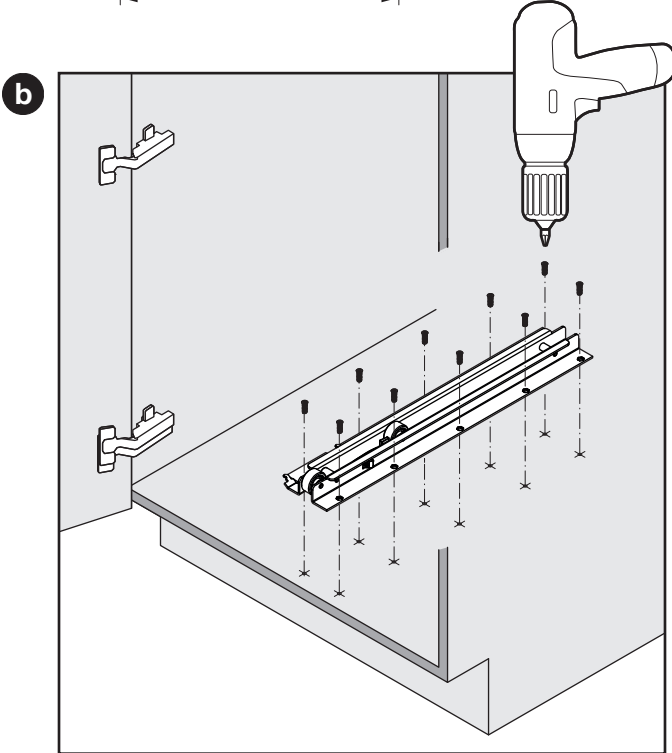
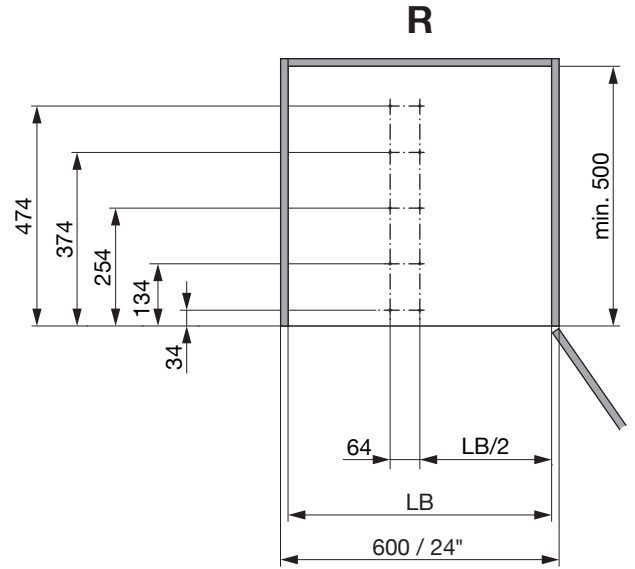
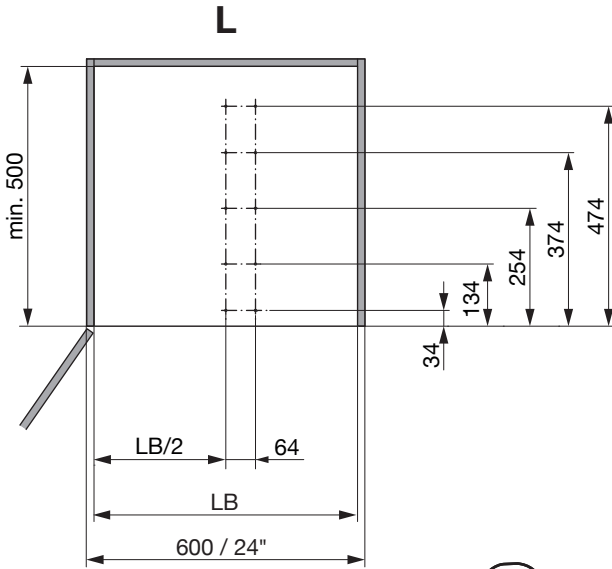
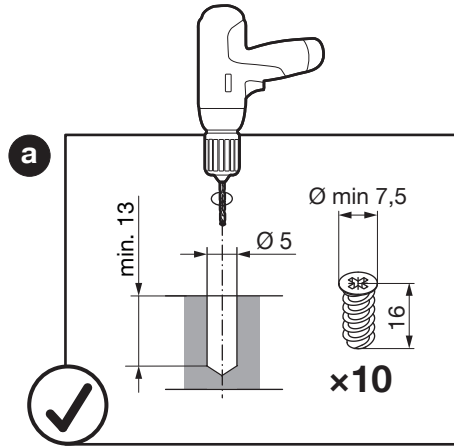
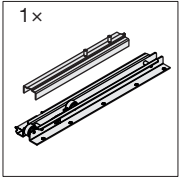

2

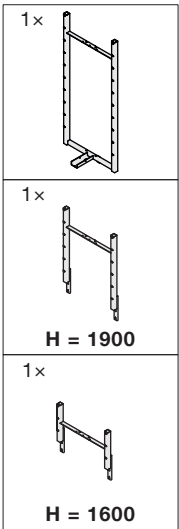

H	
1300	
1600	
1900	

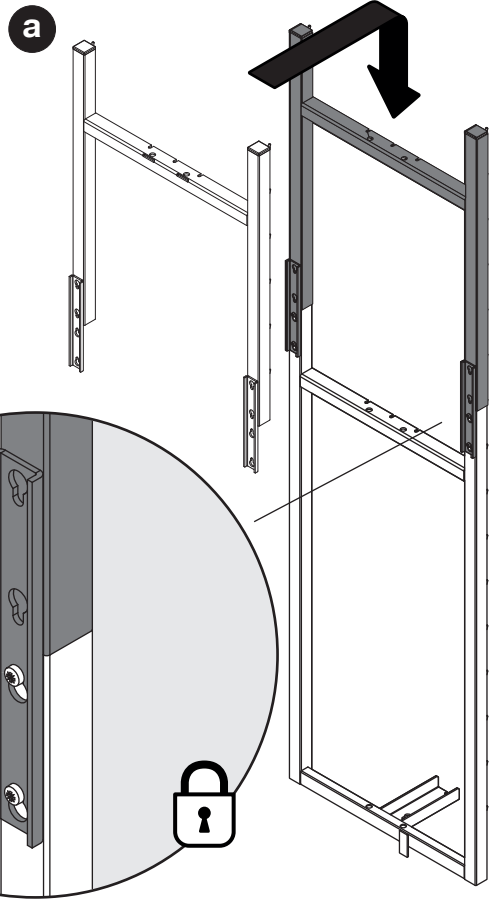
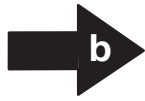

b

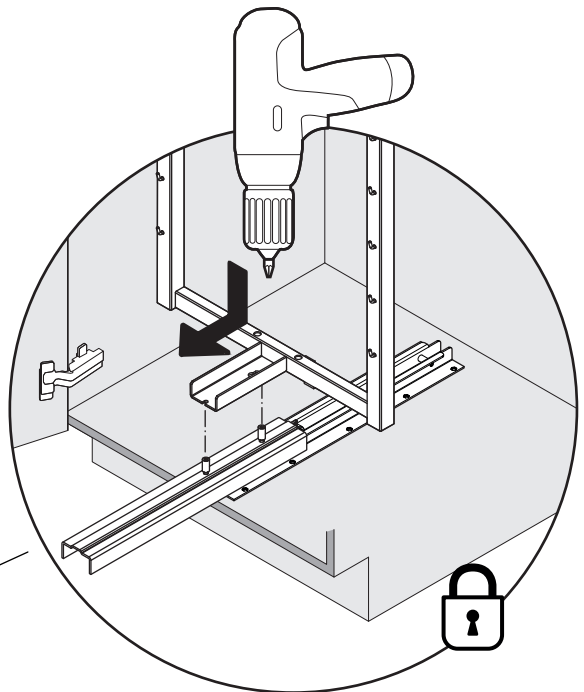
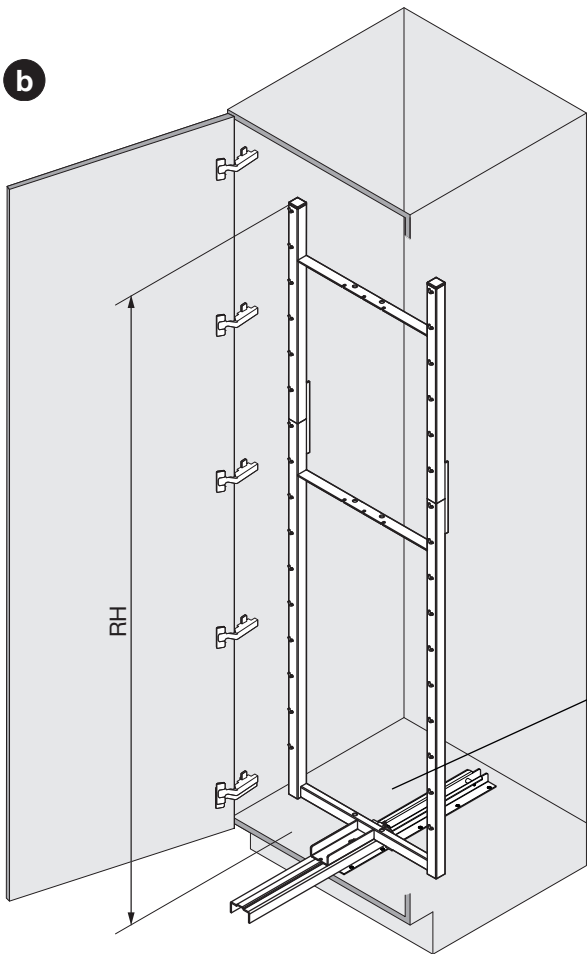

H	RH
1300	1104
1600	1412
1900	1715

3

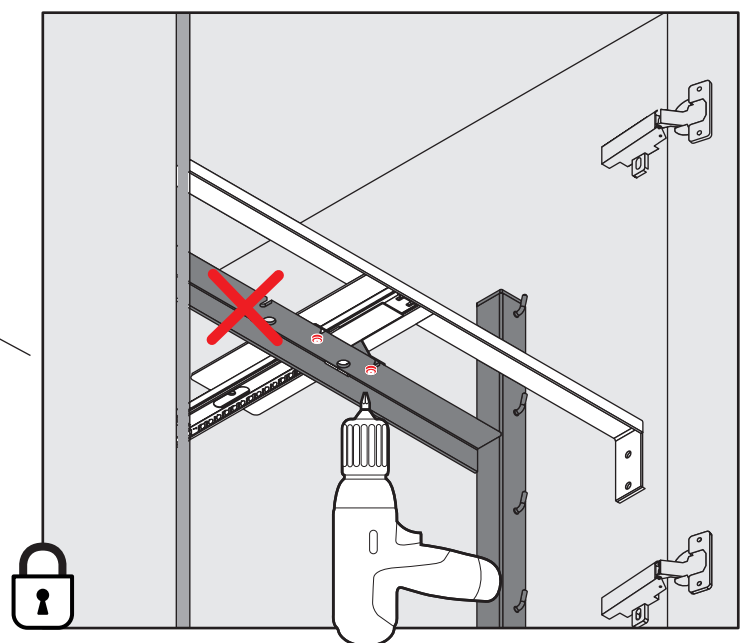
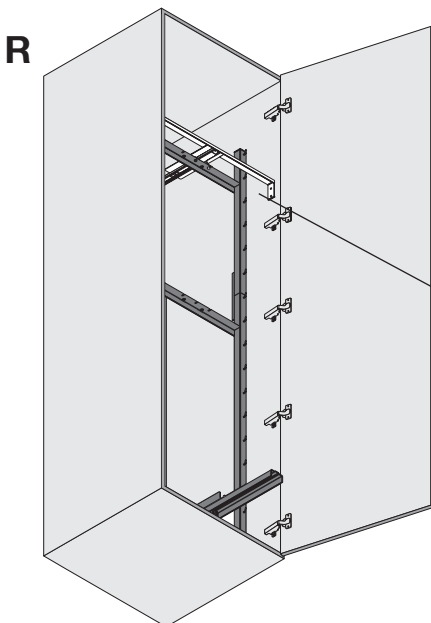
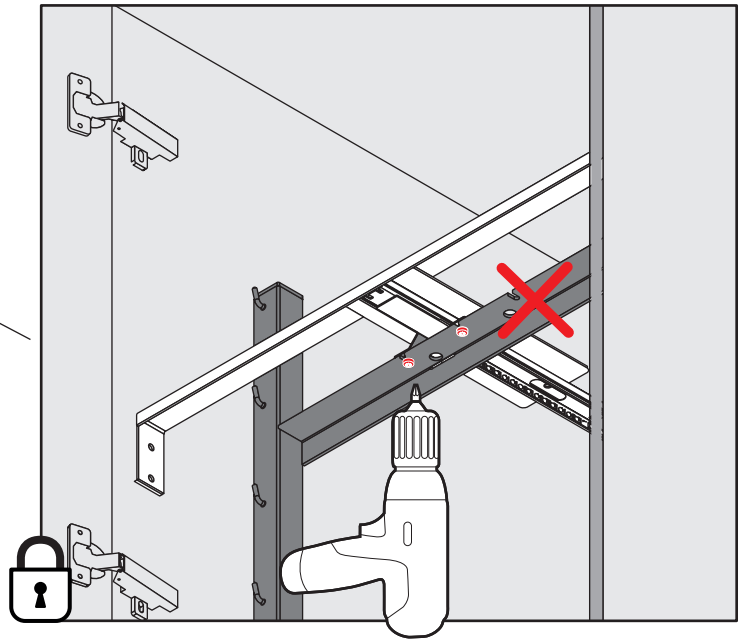
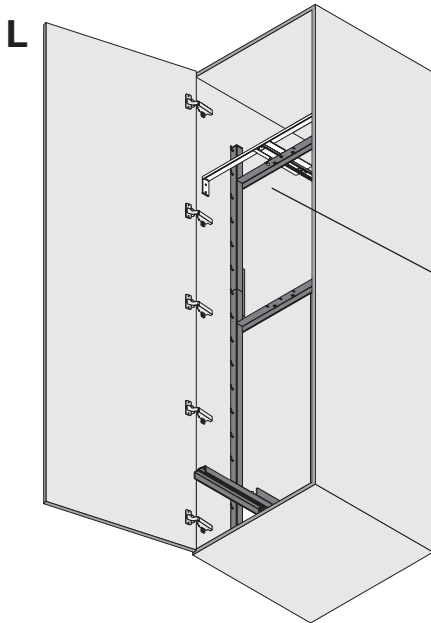
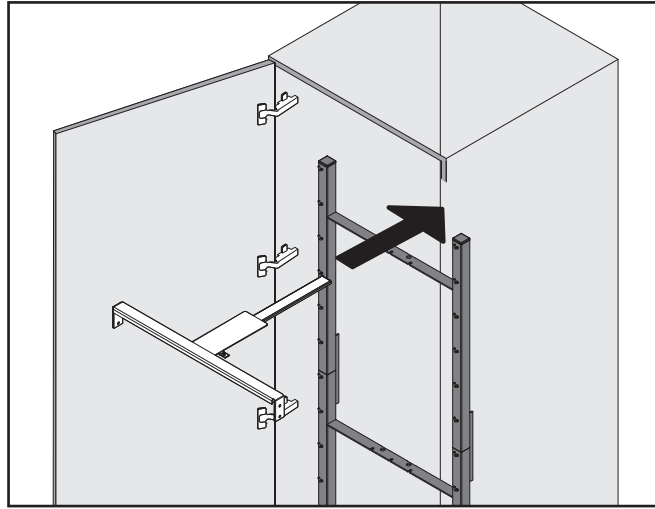
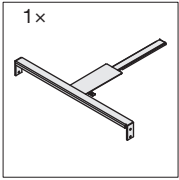

4

i

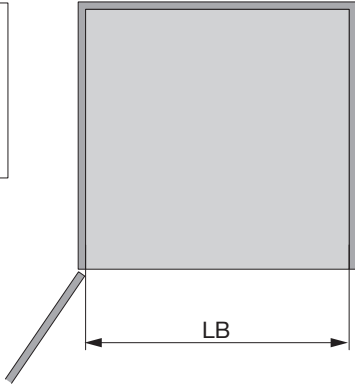
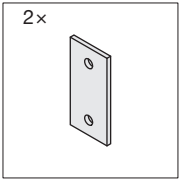

LB			
562 / 564	568	572	578
	2x		
—	—	2x 26 x 48 x 5	2x 26 x 48 x 8

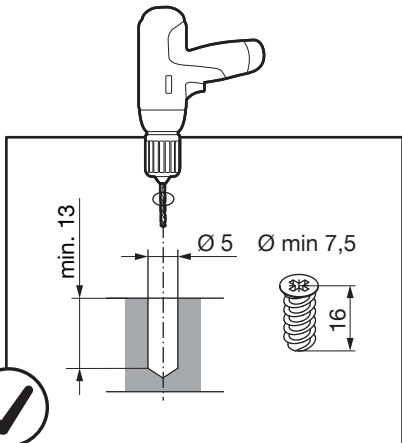
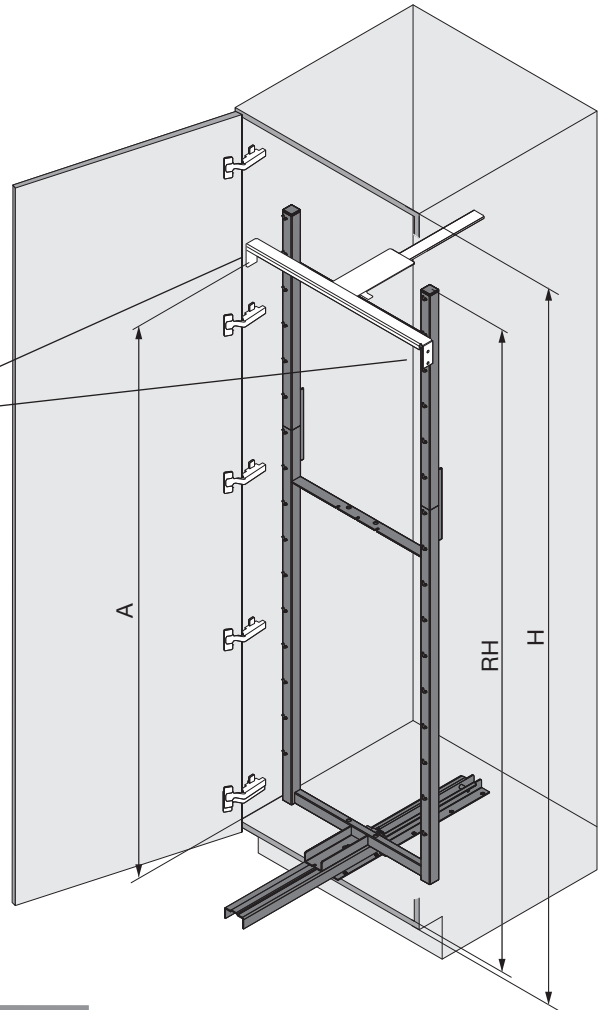
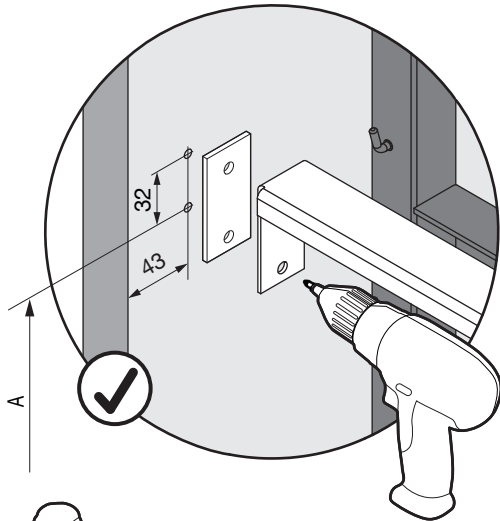

H	RH	A
1300	1104	928
1600	1412	1231
1900	1715	1534

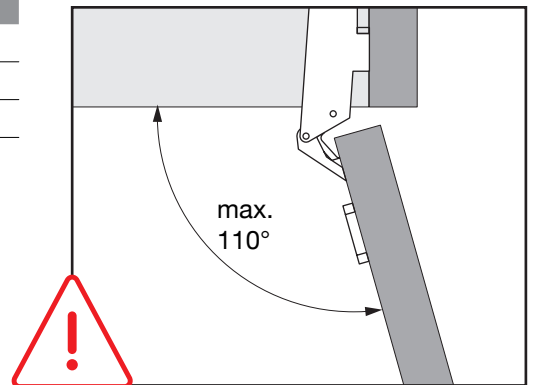
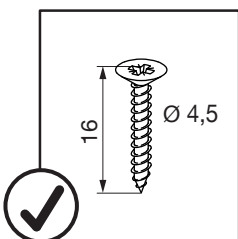

5

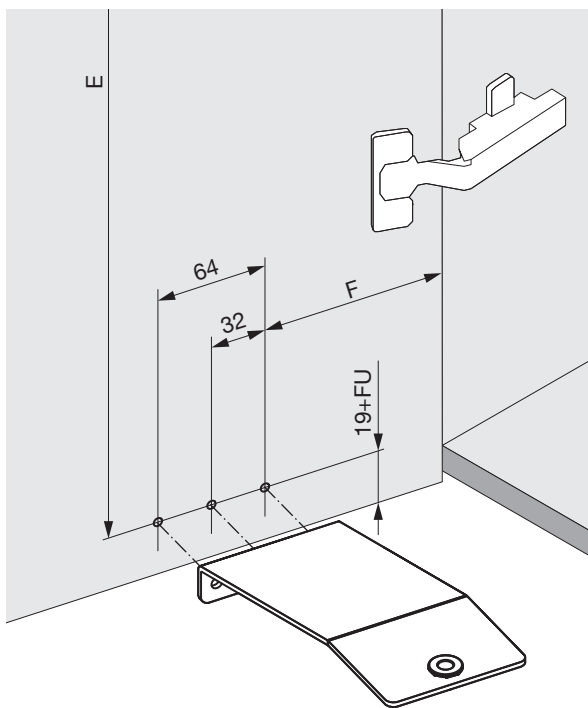
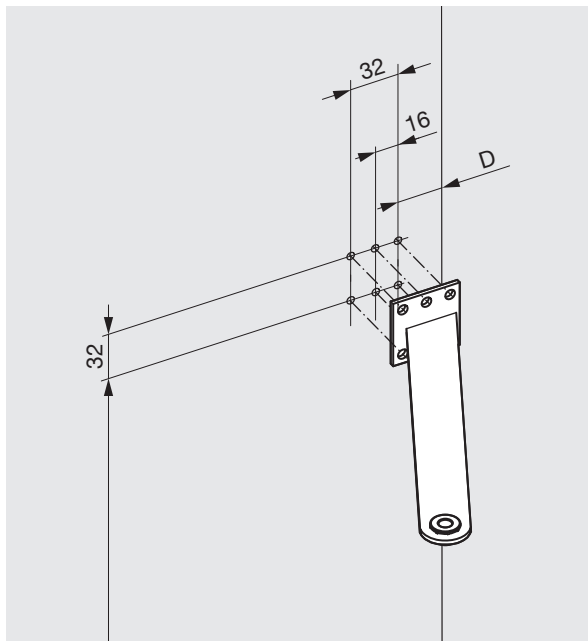
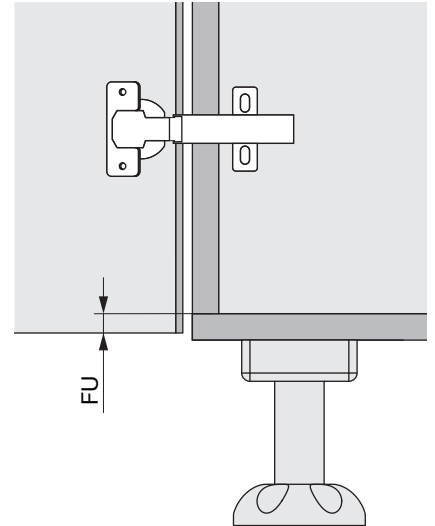
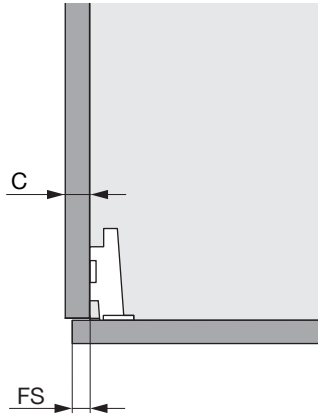
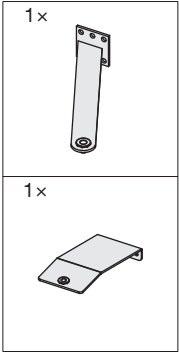

C	D	F
16	16+FS	92+FS
18	14+FS	90+FS
19	13+FS	89+FS

H	E
1300	918
1600	1221
1900	1524

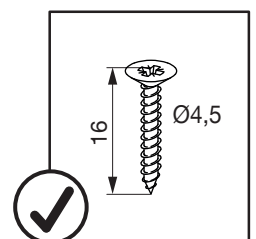
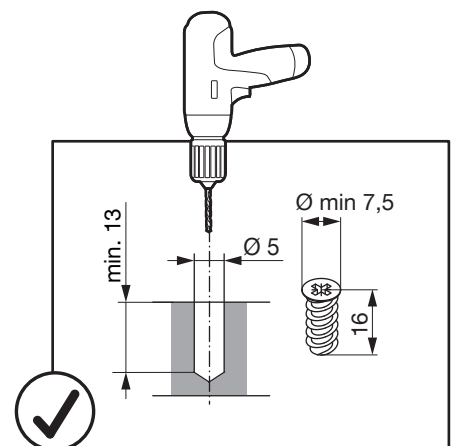

6

! **DE** Bei Rahmenfront siehe Anleitung 950.0767.MA
FR Pour façades de cadre voir l'instruction 950.0767.MA
EN For the framed front panel, see instructions 950.0767.MA

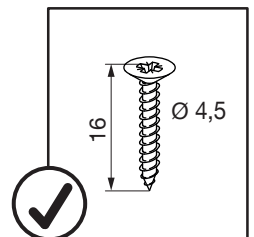
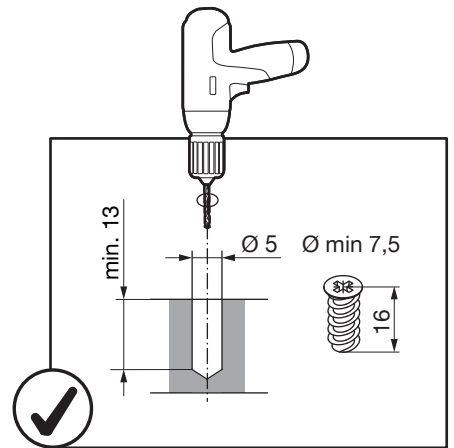
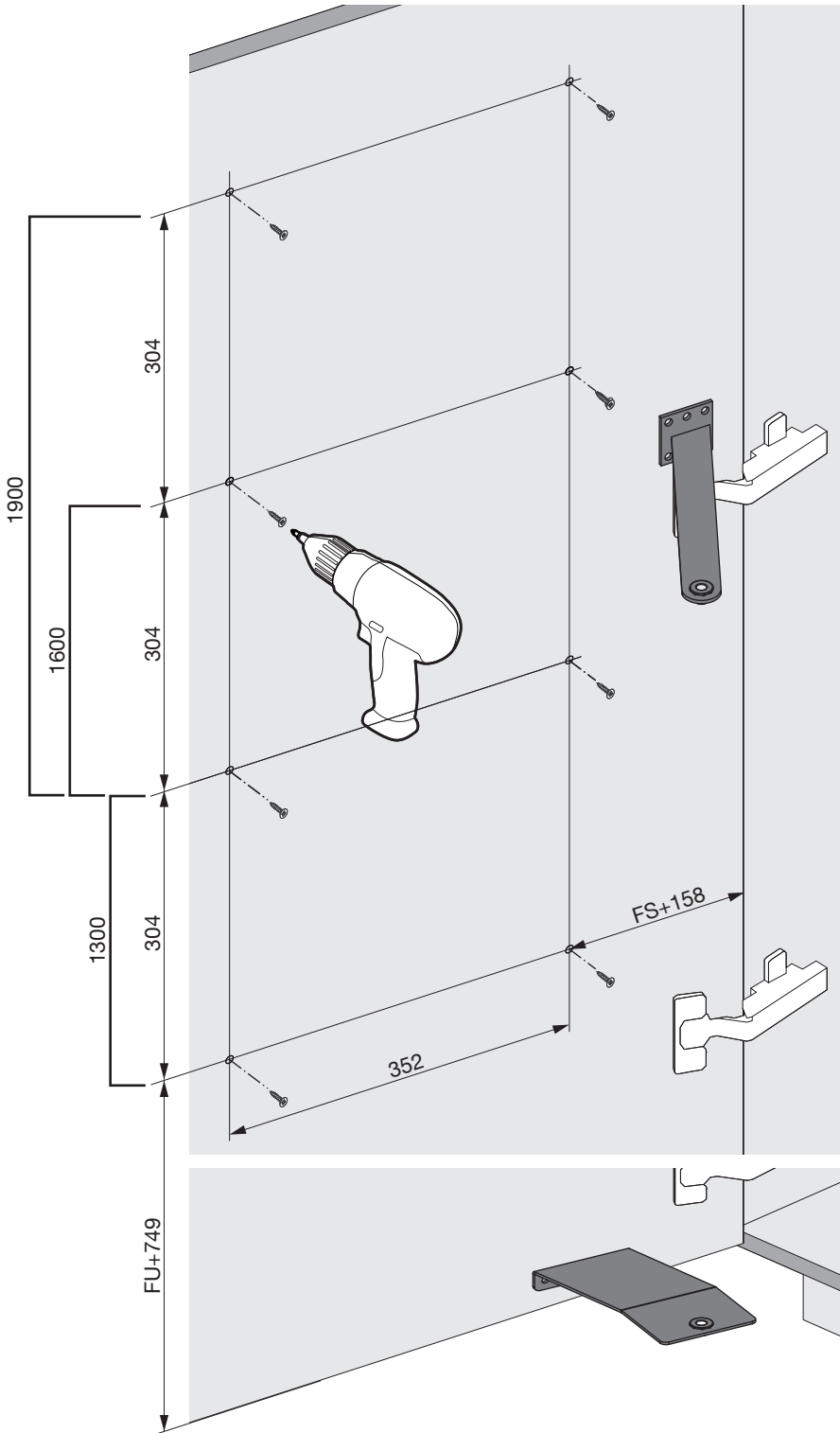
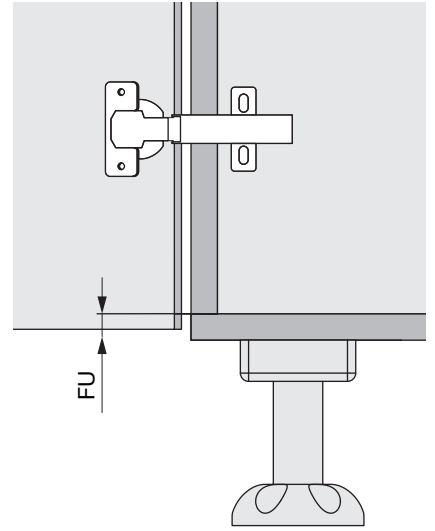
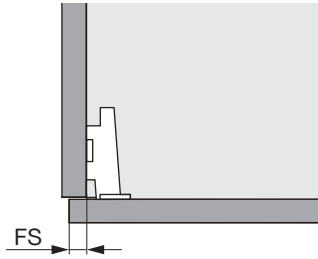
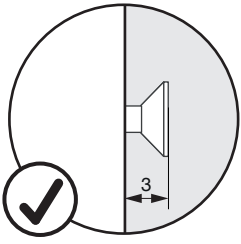

7

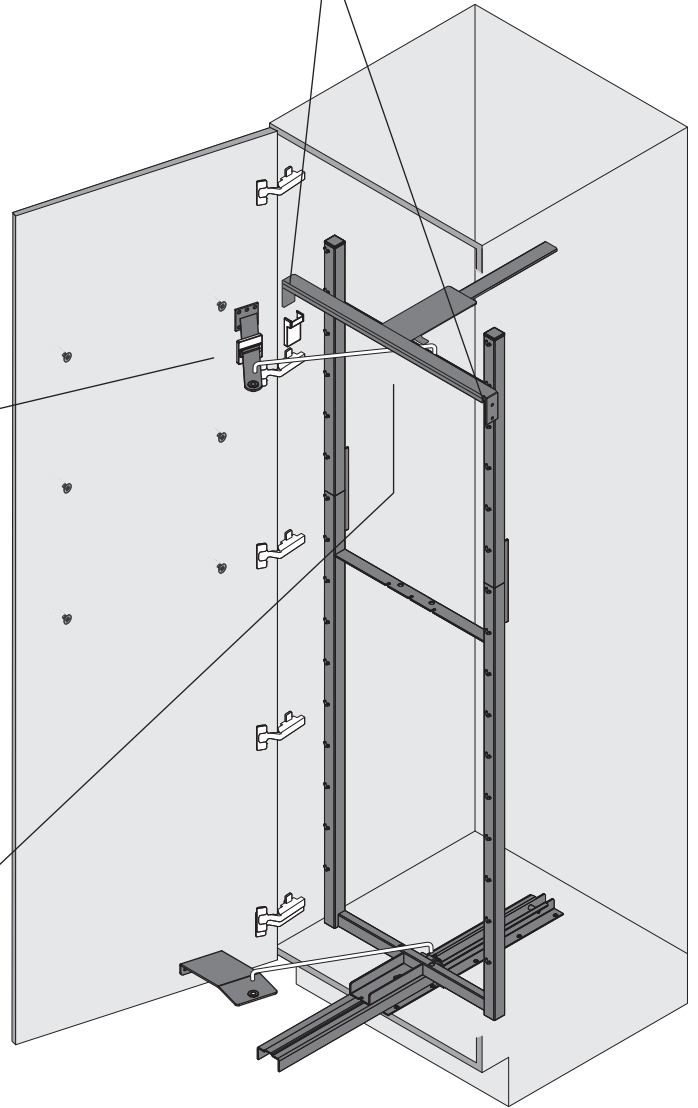
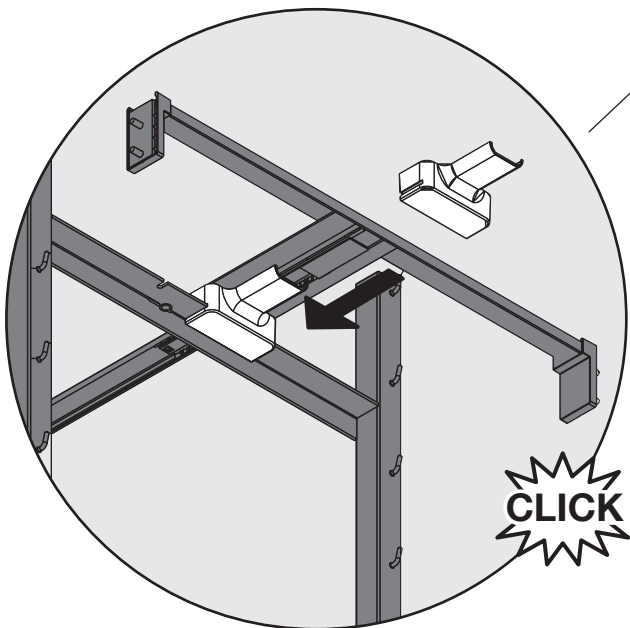
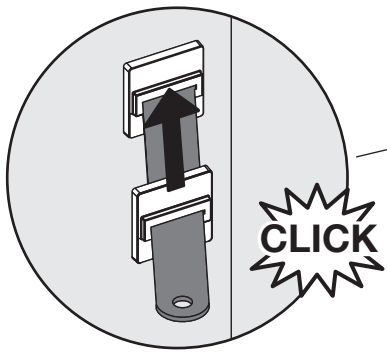
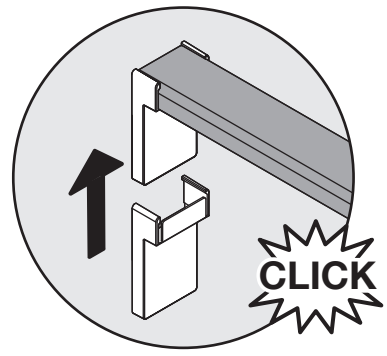
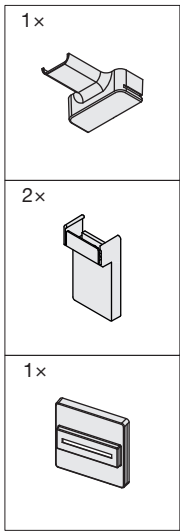

8

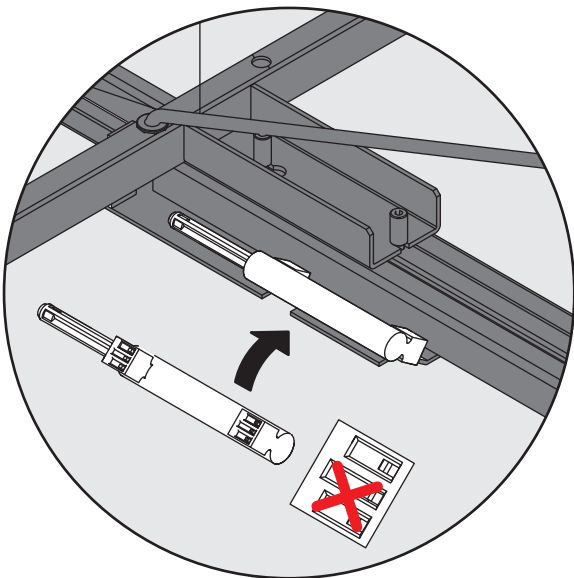
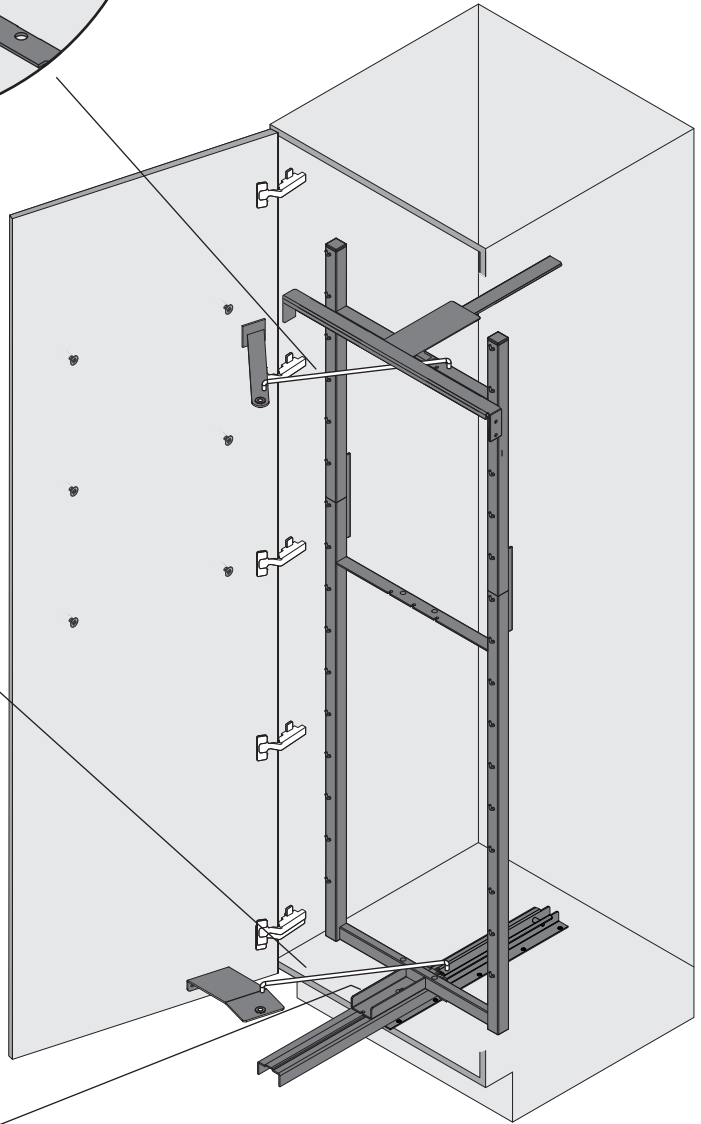
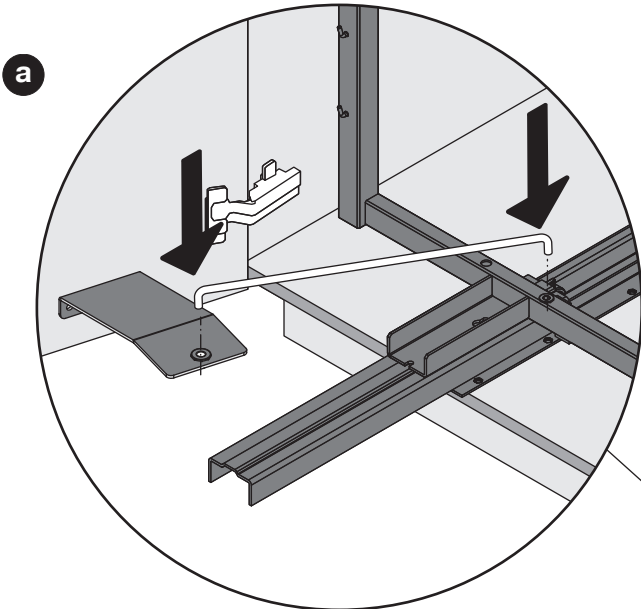
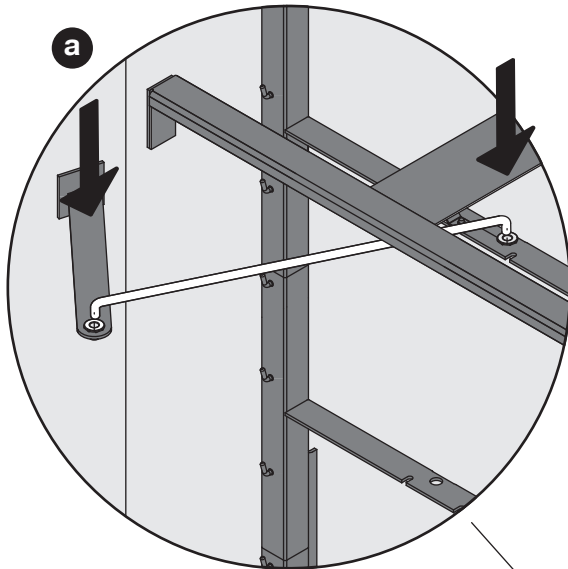
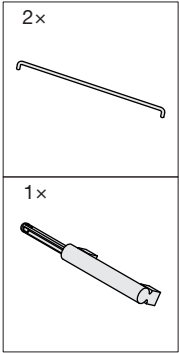

9

