

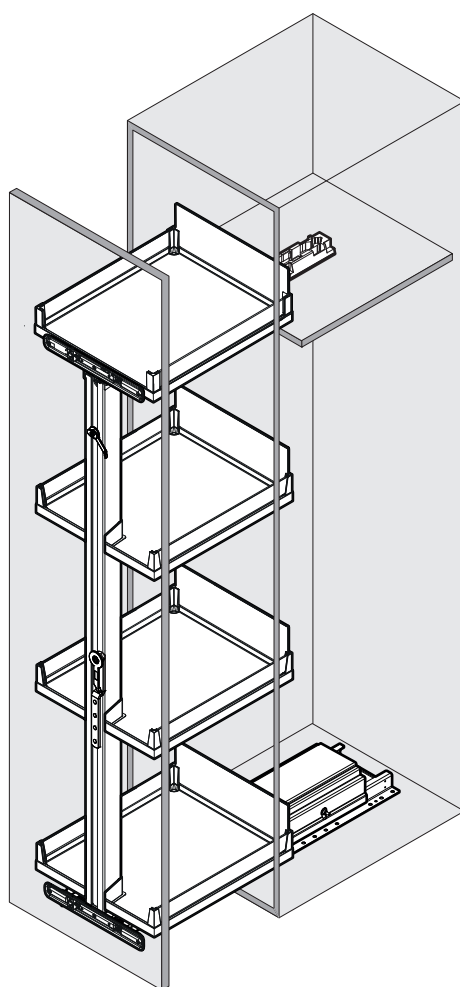







# CONVOY CENTRO

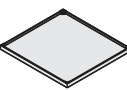

Hochschrank mit Frontauszug  
Armoire haute avec tiroir à casseroles  
Larder unit with front pull-out

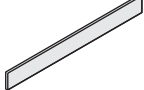

Art.Nr.  
**Typ 400**  
100.0746.xx  
**Typ 450**  
100.0747.xx

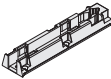
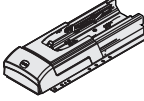
2x 	1x 	3x 
22x 	12x 	13x 

Art.Nr. 100.0626.xx	12x  ø6,3x16
1x 	1x 

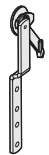
Art.Nr. <b>1900 - 1999</b> 100.0636.xx <b>2000 - 2099</b> 100.0637.xx <b>2100 - 2199</b> 100.0638.xx	1x 
1-2x 	1x 



	Symbole	Symboles	Symbols
	Warnung	Avertissement	Warning
	Korrekt	Correct	Correct
	Nicht korrekt	Incorrect	Incorrect
	Lösen/gelöst	Détacher/détaché	Release/Released
	Fixieren/fixiert	Fixer/fixé	Secure/Secured
	Klick-Geräusch beim Einrasten	«Clic» lors de l'encliquetage	Audible click on engagement
	Alle Masse in mm	Toutes les dimensions en mm	All dimensions in mm



**DE** Die Gewichts- und Beladungsangaben gelten als Maximalwert und sind abhängig von den gewählten Schrankmaterialien (ein verwindungsteifes Material - z.B. Massivholz, Spanplatten - ist zu wählen) und der Schrankkonstruktion und können dementsprechend variieren!  
 Es wird davon ausgegangen, dass geeignete Verbindungs- und ggf. Konstruktionshilfsmittel (z.B. Stützen) eingesetzt werden. Eine verbindliche Beladungsangabe obliegt dem Verarbeiter!  
 Die technischen Darstellungen und Massangaben - auch Abbildungen und Zeichnungen - sind unverbindlich. Konstruktionsverbesserungen sind vorbehalten!

**FR** Les indications relatives au poids et à la charge servent de valeurs maximales, dépendent des matériaux choisis pour l'armoire et sa structure (choisir un matériau résistant à la torsion, p. ex. bois massif, panneau d'agglomérés), et peuvent varier en conséquence !  
 On suppose que des éléments de liaison et de structure appropriés (p.ex. des supports) sont utilisés.  
 Le responsable de la transformation du meuble est tenu de définir lui-même les valeurs de la charge !  
 Les illustrations technique et les cotes - y compris sur les schémas et les dessins - sont non contractuelles.  
 Sous réserve d'améliorations de la construction !

**EN** The weight and load specifications are given as maximum values and depend on the selected cupboard materials (a warp resistant material, such as solid wood or chipboard, should be chosen) and cupboard design so they may vary accordingly!  
 It is assumed that suitable fasteners and, if required, construction hardware (e.g. supports) will be used.  
 The fabricator is responsible for binding load specifications!  
 Technical information and stated dimensions (including in illustrations and drawings) must not be regarded as binding.  
 Design subject to change without notice (in interest of improvement)!

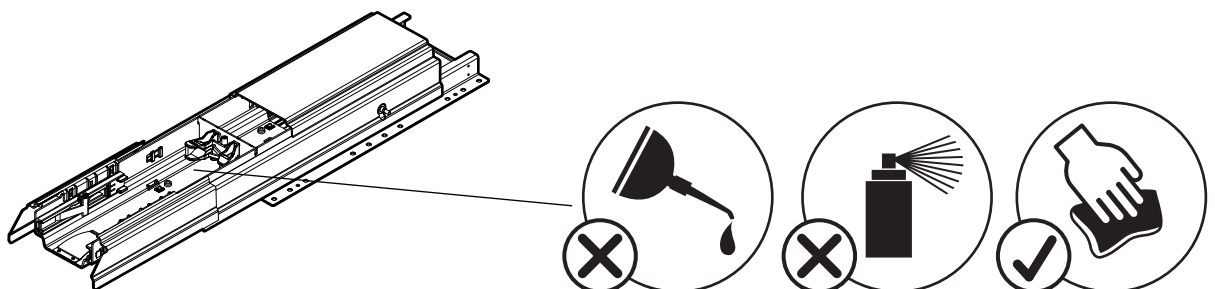



**!** Hochschrank gegen Kippen sichern!  
 Sécuriser l'armoire contre le basculement !  
 Secure the larder unit against tilting over!

LH	A	C
1900-1999	1530	1567
2000-2099	1630	1667
2100-2199	1730	1767

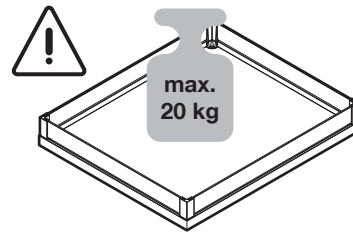
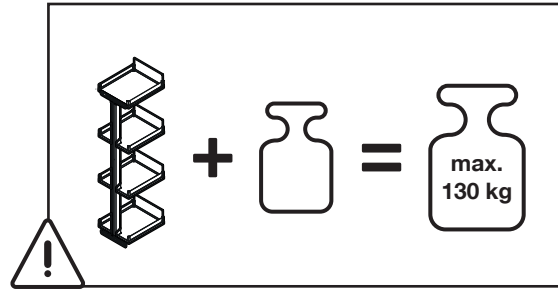
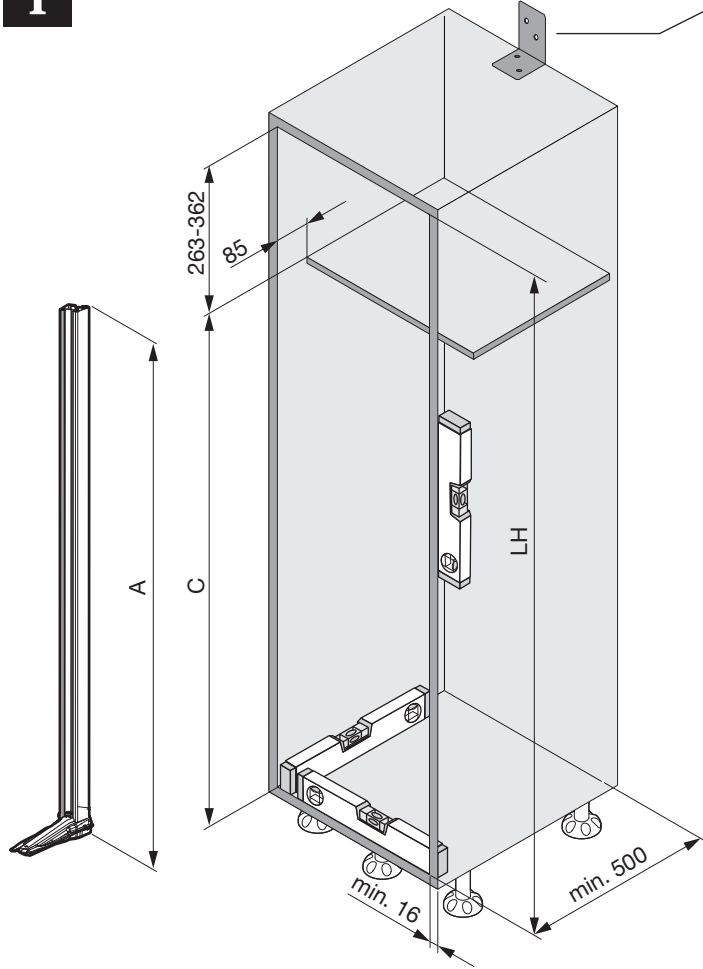

**1**

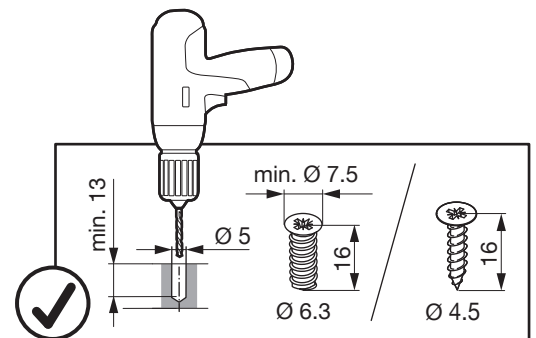
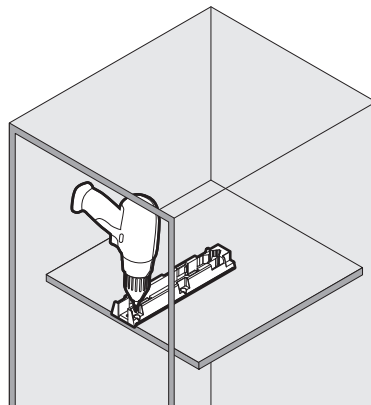
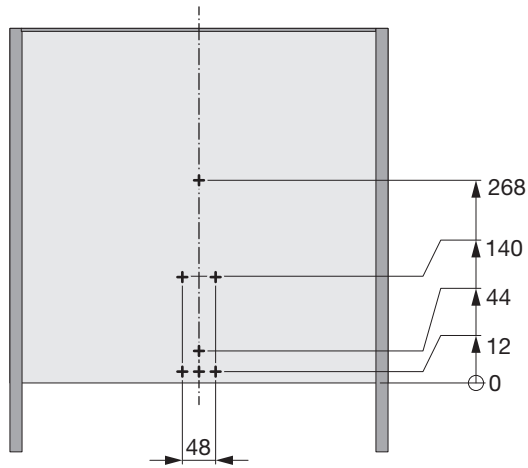
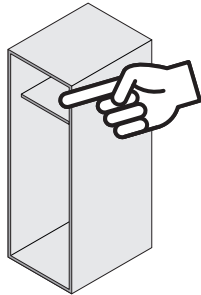
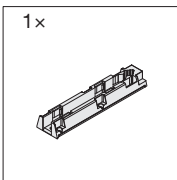

2

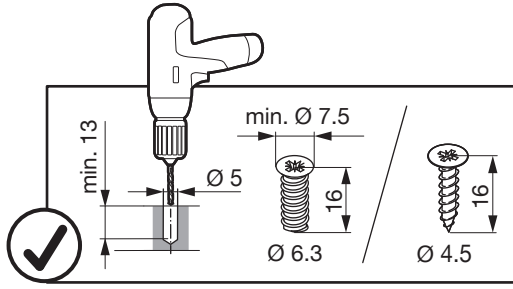
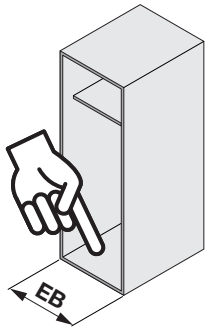

**EB= 400**

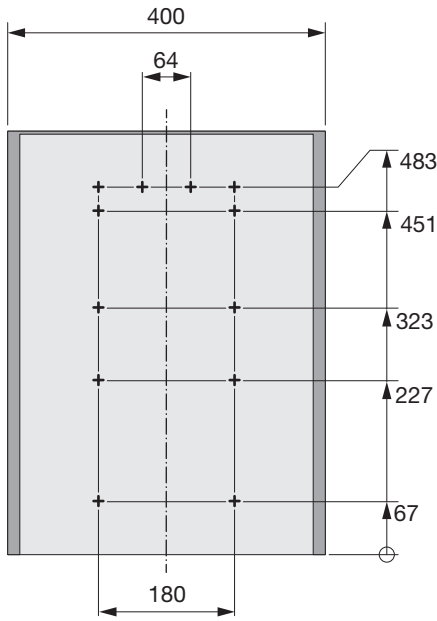
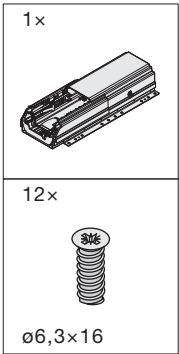

**EB= 450**

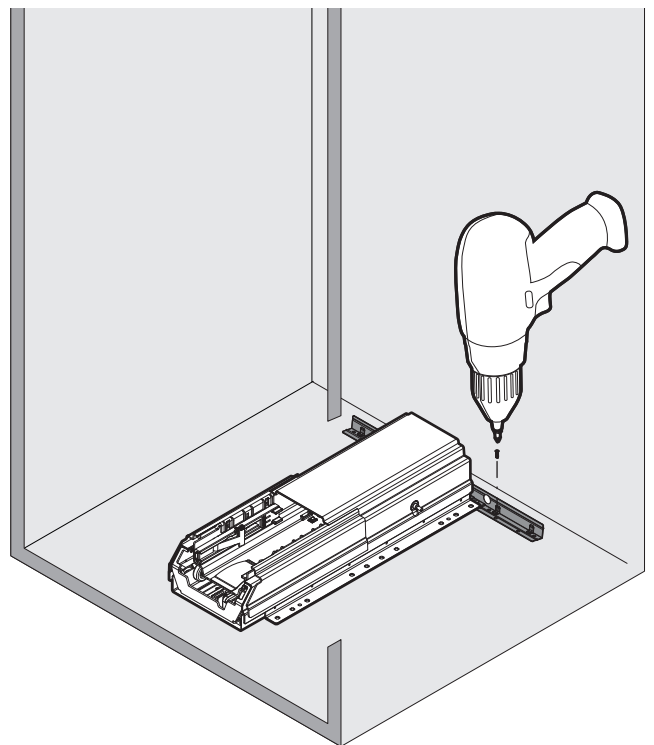
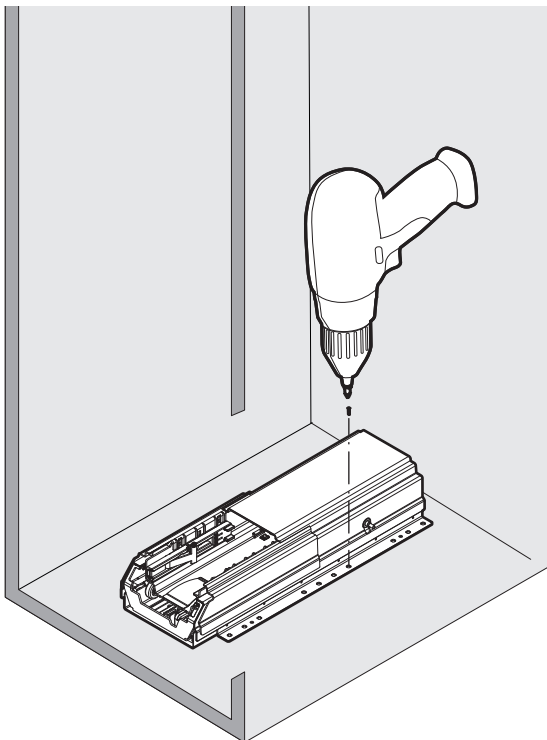
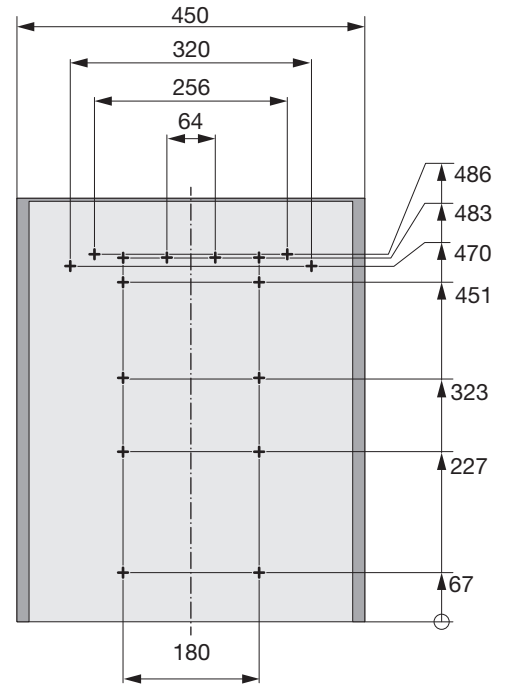
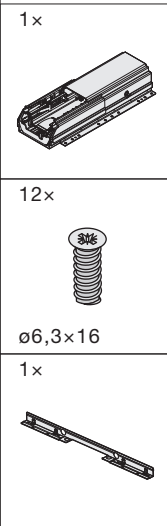

# 3

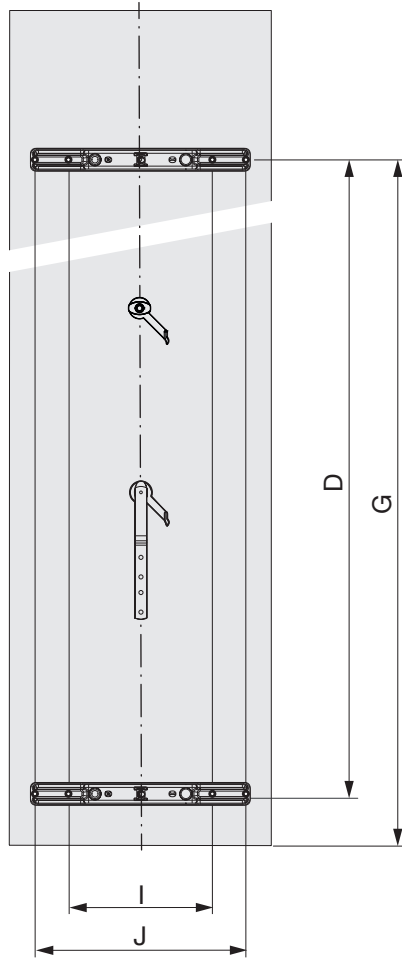
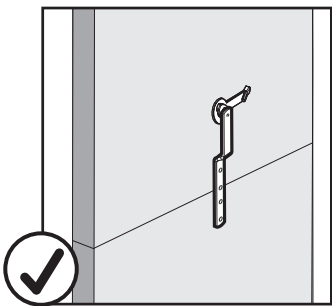
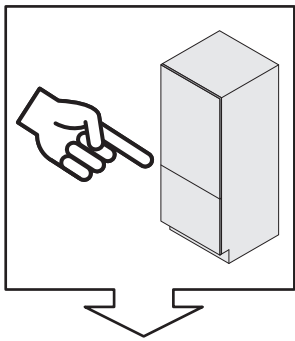
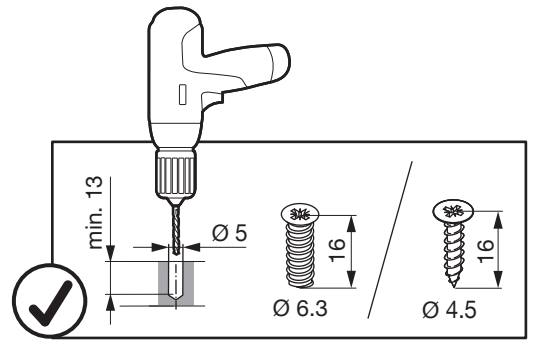
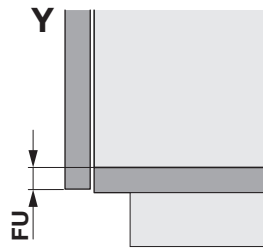
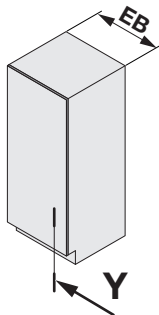
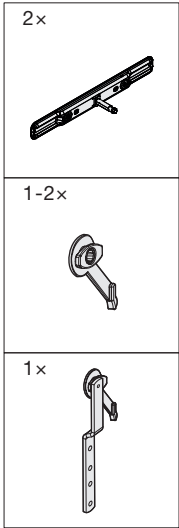

LH	D	G
1900-1999	1516	1600 + FU
2000-2099	1616	1700 + FU
2100-2199	1716	1800 + FU

EB	I	J
400	-	322
450	247	372

# 4

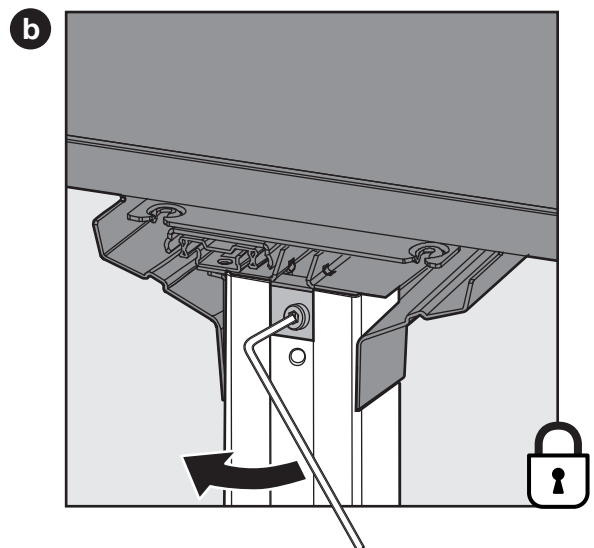
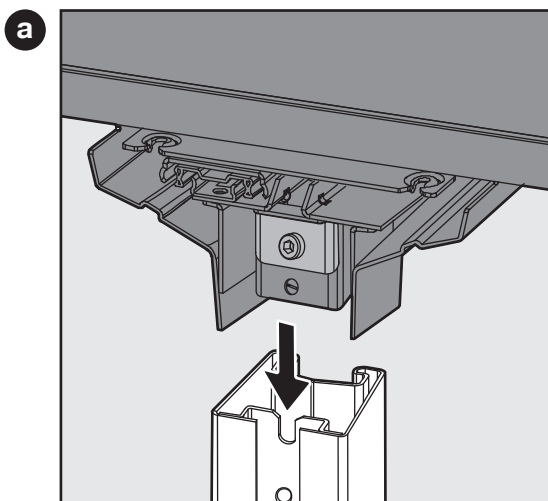
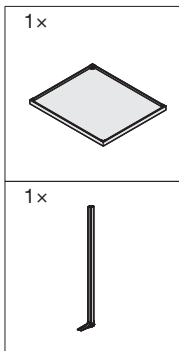

5

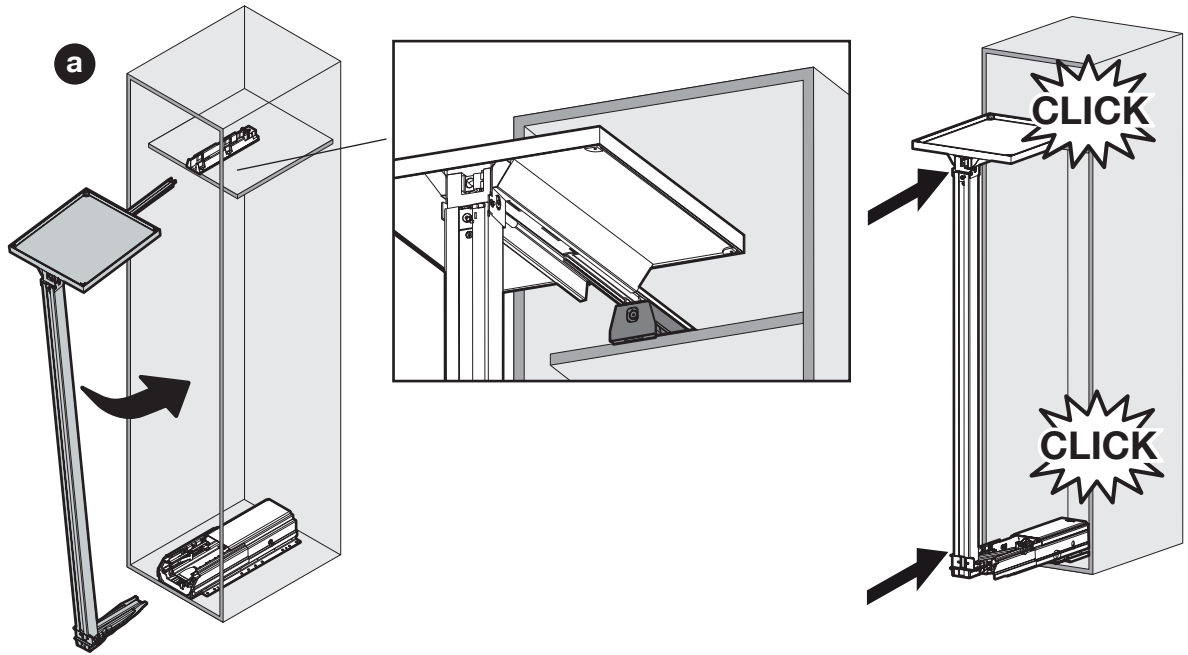

6

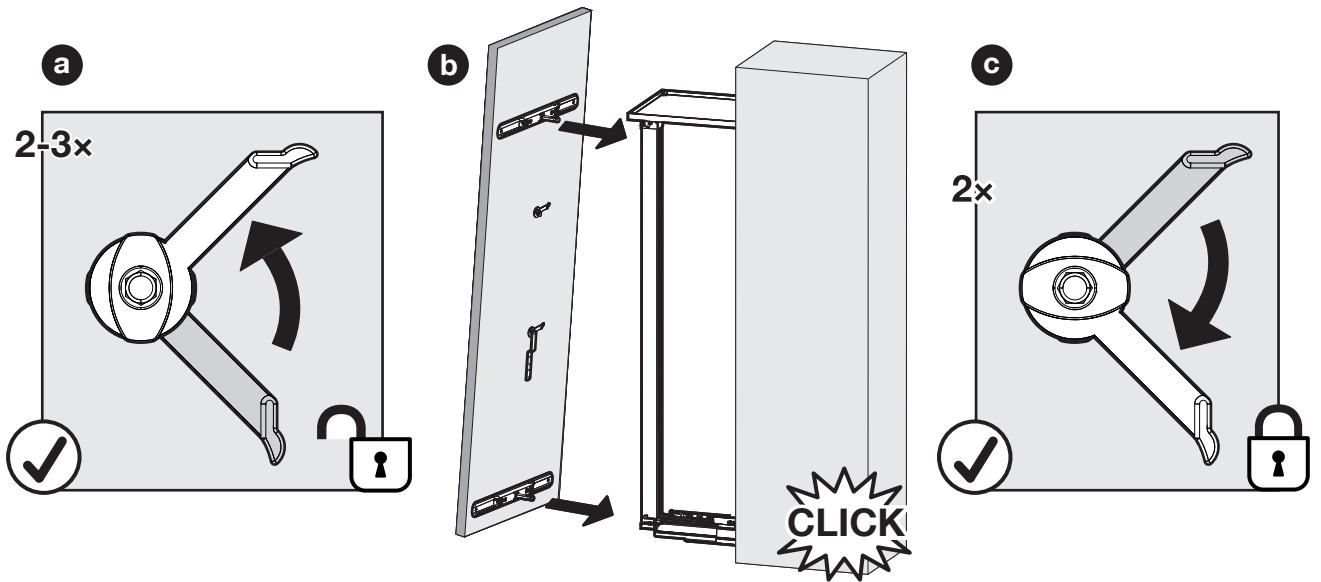

7

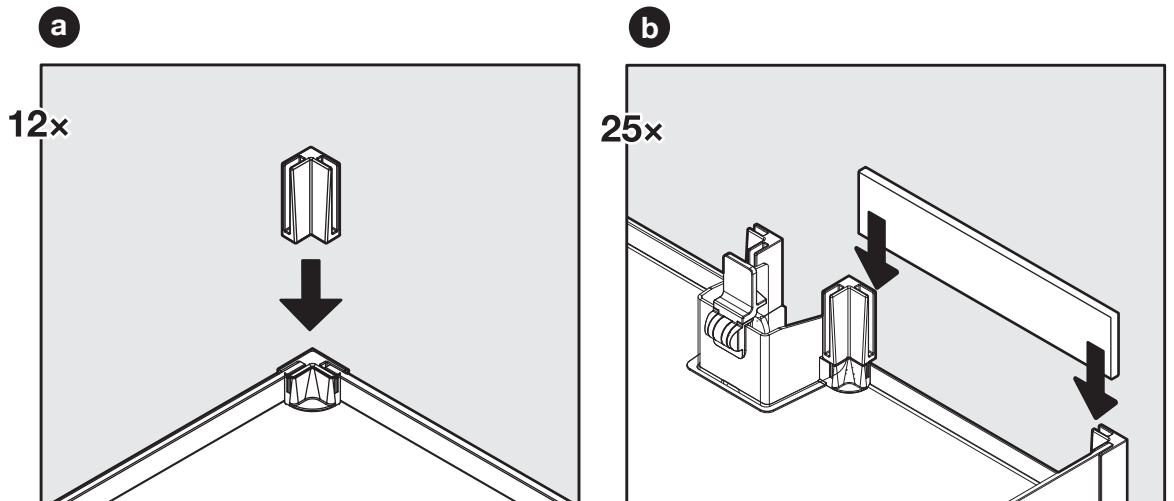
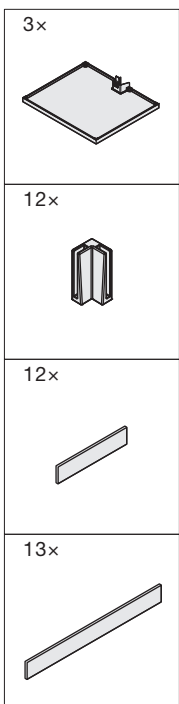

8

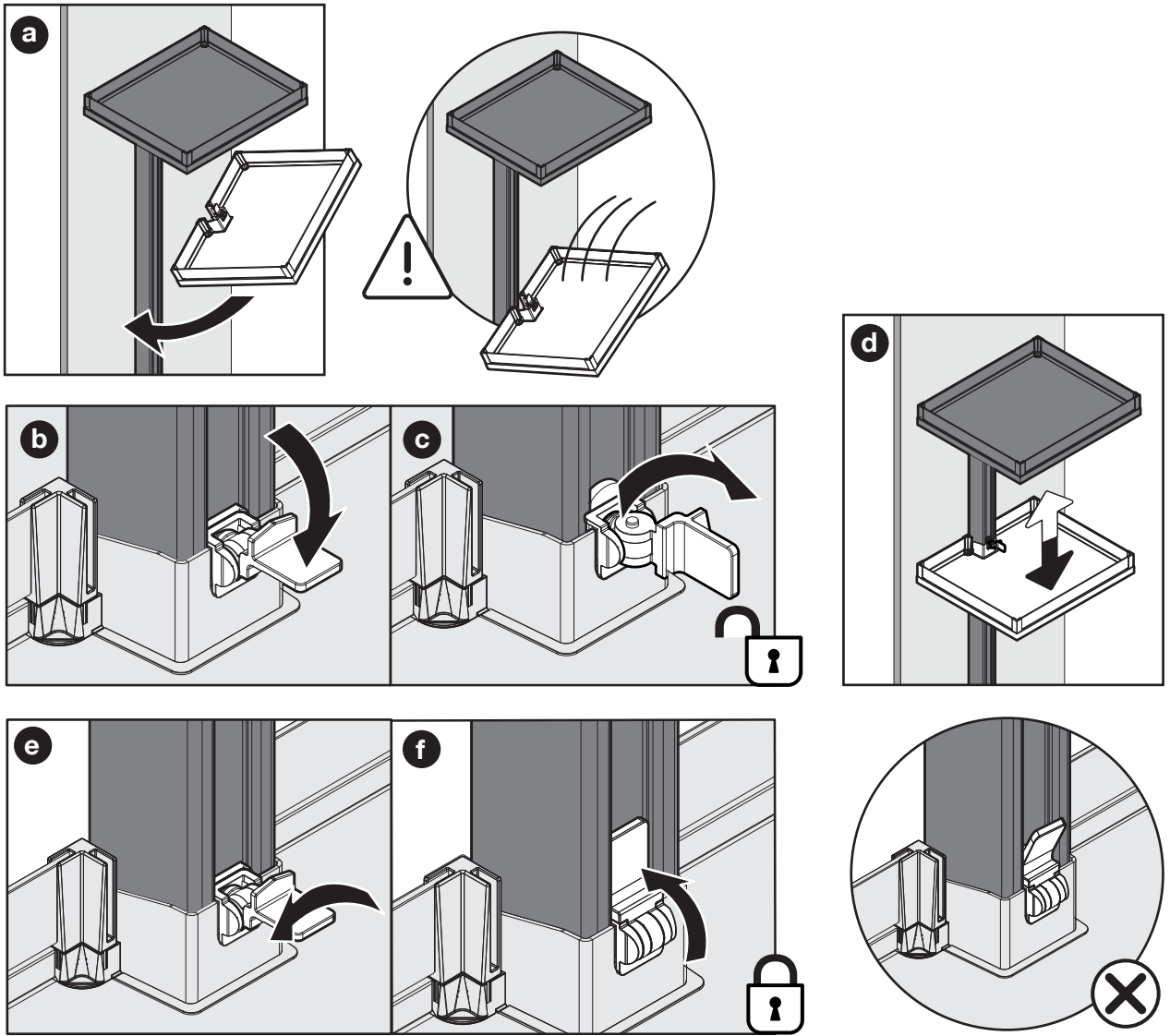

i

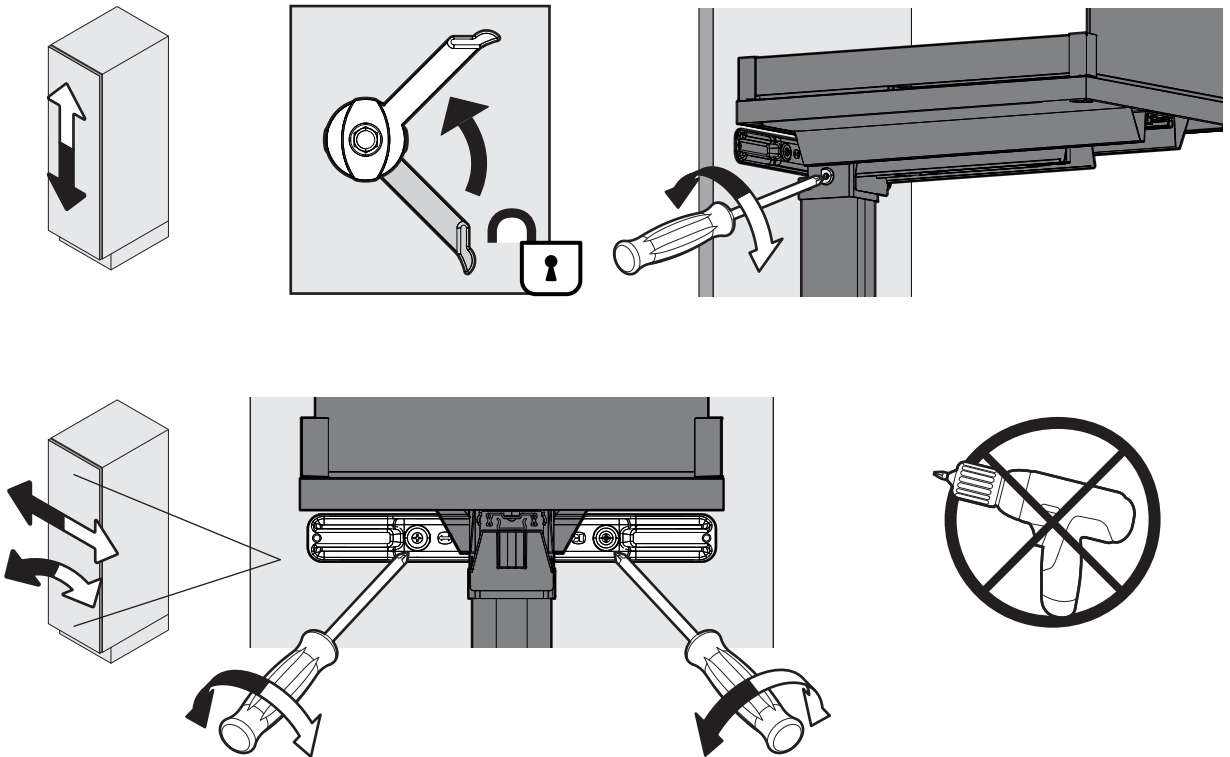

**i**

